

REV.	ECN NO.	OR DESCRIPTION	REVISED	DATE
A	PDRNO:S131017-13A&13B	Harlen	2013.11.4	
B	ECN NO:S140336	Harlen	2014.3.25	
C	ECN NO.:S151212-C	Vicky	2016.03.16	
D	ECN NO.:S160801-R	Yang	2016.08.01	

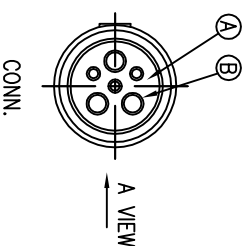

P/N	L
ZEB3004-W06916H	1200±10
ZEB3004-W06917H	1250±10
6	BLACK
5	YELLOW
4	WHITE
3	BLUE
2	RED
1	GREEN
CONN.	WIRE COLOR
	PIN OUT
	CONN.

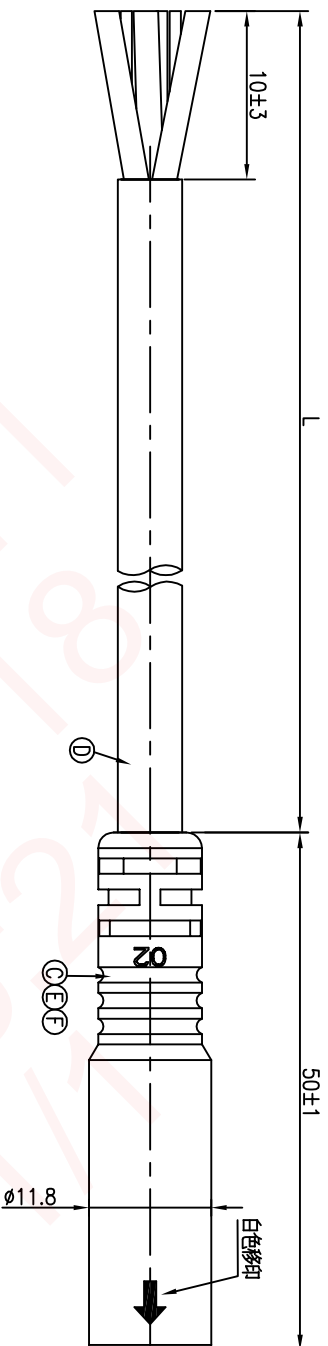
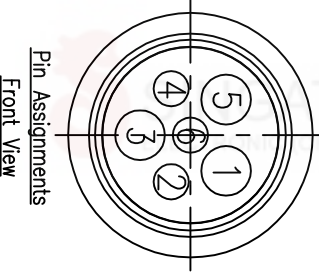

- NOTES:
1. WATERPROOF RATE: IP65
  2. CURRENT RATING: 10A+2A
  3. CONTACT RESISTANCE: 3 Ohm Max.
  4. HI-POT TEST 800V AC, 5mA(1SEC)
  5. INSULATION RESISTANCE: 30Mohm MIN. BY 500V DC
  6. SPECIFICATIONS:SEE "E-BIKE SERIES SPECIFICATIONS"
  7. TO CONFORM TO THE SINGATRON HAZARDOUS SUBSTANCE FREE SPEC.
  8. GREEN PRODUCT IDENTIFICATION LABEL ON PACKAGING:

A VIEW

F	SHRINK TUBE	3	1.5mm 300V	BLACK
E	INNER MOLD	1	PVC	BLACK
D	CABLE	1	16#*3C+24#*3C OD6.2	BLACK(PVC JACKET)
C	OVER MOLD	1	HYTREL	BLACK
B	FEMALE PIN	6	Phosphor Bronze	1~3u" GOLD PLATING OVER NICKEL PLATING
A	BODY	1	PA66+30%GF	BLACK
UNLESS OTHERWISE SPECIFIED TOLERANCES				
Singatron Enterprise Co., Ltd. 信譽企業股份有限公司				
TITLE: E-BIKE SERIES 180° 6 PIN FEMALE CONN.				
DWN	Yang	PART NO.	ZEB3004-W06916H~17H	
CHKD	JF	SCALE	2:1	UNIT: mm
APVD	Harlen	SIZE:	A3	SHEET: 1 OF 1
REVISION: REV: D				
CUSTOMER COPY				