

REV.	ECN NO.	OR DESCRIPTION	REVISED	DATE
A	PDR NO.:S150428-2B	Lin		2015.05.12
B	ECN NO.: S151212-C	Ycky		2016.03.16
C	ECN NO.:S160801-R	Yang		2016.08.01

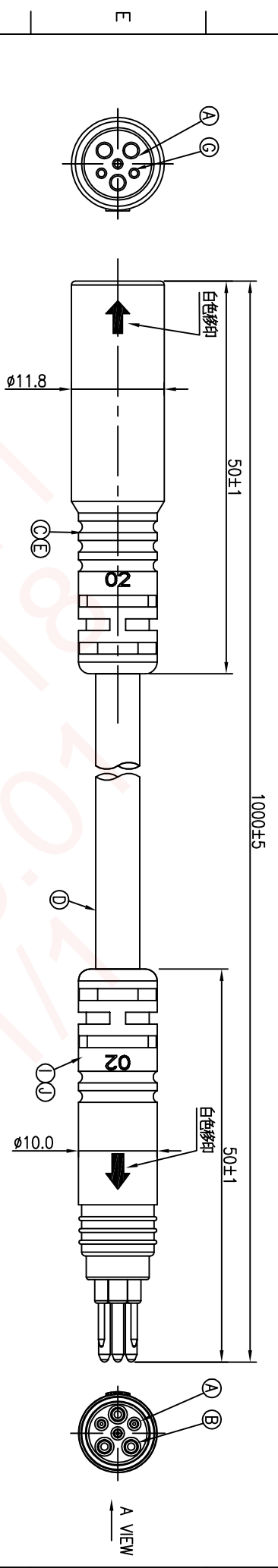

CONN.1	WIRE COLOR	CONN.2
6	BLACK	6
5	YELLOW	5
4	WHITE	4
3	BLUE	3
2	RED	2
1	GREEN	1

PIN OUT

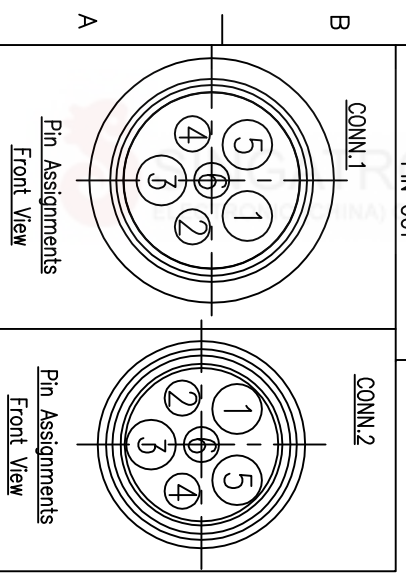

- NOTES:
1. WATERPROOF RATE: IP65
 2. CURRENT RATING: 10A+2A
 3. CONTACT RESISTANCE: 3 Ohm Max
 4. HI-POT TEST 800V AC, 5mA(1SEC)
 5. INSULATION RESISTANCE: 30Mohm MIN. BY 500V DC
 6. SPECIFICATIONS:SEE "E-BIKE SERIES SPECIFICATIONS."
 7. TO CONFORM TO THE SINGATRON HAZARDOUS SUBSTANCE FREE SPEC.
 8. GREEN PRODUCT IDENTIFICATION LABEL ON PACKAGING:

J	INNER MOLD	1	ABS	NATURAL
I	OVER MOLD	1	TPU	BLACK
H	SHRINK TUBE	6	Ø1.5mm 300V	BLACK
G	FEMALE PIN	6	Phosphor Bronze	1~3u" GOLD PLATING OVER NICKEL PLATING
F	CAP	1	PA66	NATURAL
E	INNER MOLD	1	PVC	BLACK
D	CABLE	1	16#*3C+24#*3C OD6.2	BLACK(PVC JACKET)
C	OVER MOLD	1	HYTREL	BLACK
B	MALE PIN	6	BRASS	1~3u" GOLD PLATING OVER NICKEL PLATING
A	BODY	2	PA66+GF	BLACK

UNLESS OTHERWISE SPECIFIED TOLERANCES

DECIMALS: ANGLES:

X :±0.5 X :±2
 X.X :±0.3 X.X :±1
 X.XX :±0.2

Singatron Enterprise Co., Ltd.
 信譽企業股份有限公司

TITLE E-BIKE SERIES 180° 6 PIN CONN.
 DWG Yang PART NO.2EBB3004-W06933H
 CHKD JF SCALE 2:1 UNIT: mm
 APVD Harlen SIZE: A3 SHEET: 1 OF 1 REV:C

CUSTOMER COPY