

REV.	ECN NO OR DESCRIPTION	REVISED	DATE
A	PDR NO.:S150907-2A	Yicky	2016.03.16
B	ECN NO.:S160801-R	Yang	2016.08.01

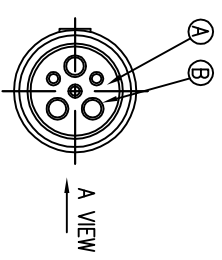

6	BLACK
5	YELLOW
4	WHITE
3	BLUE
2	RED
1	GREEN
CONN. WIRE COLOR	
PIN OUT	
CONN.	

- NOTES:
1. ELECTRICAL CHARACTERISTICS:
- 1-1 CURRENT RATING: (10+2) AMPS.
 - 1-2 CONTACT RESISTANCE: 3 Ohm Max.
 - 1-3 INSULATION RESISTANCE: 30 MOhm Min. at 500VDC.
 - 1-4 BREAKDOWN VOLTAGE: 800 VAC PER MINUTE.
2. ENVIRONMENTAL:
- 2-1 OPERATING TEMPERATURE: -20°C TO +80°C.
 - 2-2 SEALING REQUIREMENTS: IP65.
3. SPECIFICATIONS:SEE "E-BIKE SERIES SPECIFICATIONS".
4. FOR TECHNICAL DATA REFER TO YOUR LOCAL SINGATRON ELECTRONICS SALES OFFICE.
5. ALL DIMENSIONS ARE NOMINAL FOR REFERENCE ONLY UNLESS OTHERWISE STATED.
6. TO CONFORM TO SINGATRON HAZARDOUS SUBSTANCE FREE SPEC.
7. GREEN PRODUCT IDENTIFICATION LABEL ON PACKAGING:

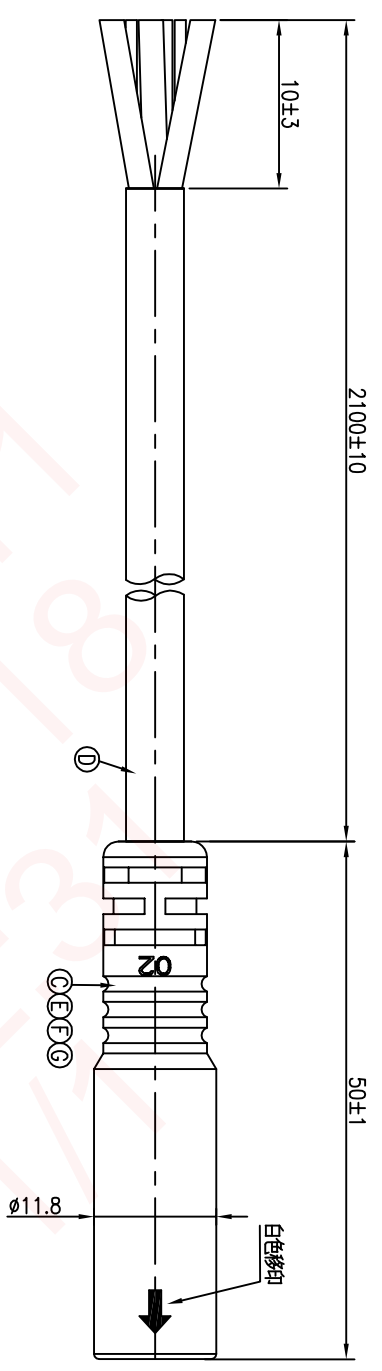
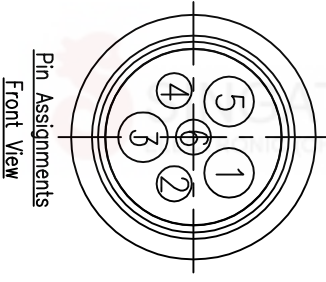

Pin Assignments
Front View

A VIEW

G	SHRINK TUBE	3	φ1.5mm 300V	BLACK
F	SHRINK TUBE	3	φ2.5mm 600V	BLACK
E	INNER MOLD	1	PVC	BLACK
D	CABLE	1	16#*3C+24#*3C OD5.6	BLACK(PVC JACKET)
C	OVER MOLD	1	HYTREL	BLACK
B	FEMALE PIN	6	Phosphor Bronze	1~3u" GOLD PLATING OVER NICKEL PLATING
A	BODY	1	PA66+30%GF	BLACK
NO	DESCRIPTION	QTY	MATERIAL	PLATING & COLOR

UNLESS OTHERWISE SPECIFIED TOLERANCES

DECIMALS:	ANGLES:
X :±0.5	X :±2°
X.X :±0.3	X.X :±1'
X.XX :±0.2	

Singatron Enterprise Co., Ltd.
 信譽企業股份有限公司

TITLE	SCALE	SHEET	REV.
E-BIKE SERIES 180° 6 PIN FEMALE CONN.	2:1	1 OF 1	B

DWG: Yang PART NO. 2EB3004-W06939H
 CHKD: JF SCALE 2:1 UNIT: mm
 APVD: Harlen SIZE: A3 SHEET: 1 OF 1 REV: B

CUSTOMER COPY