

REV.	ECN NO OR DESCRIPTION	REVISED	DATE
B	ECN NO.: S160801-R	Harlen	2016.08.01
C	ECN NO.: S161148-C	Vicky	2016.11.11

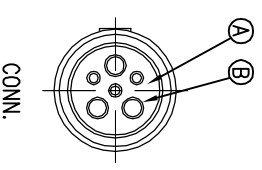

CONN.	WIRE COLOR
1	GREEN
2	RED
3	BLUE
4	WHITE
5	YELLOW
6	BLACK

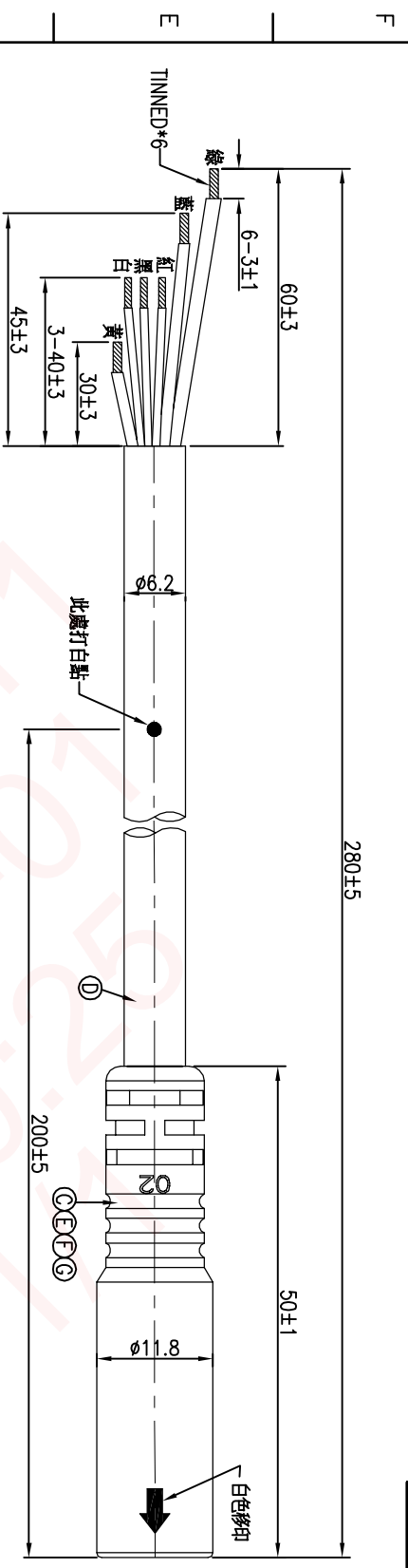
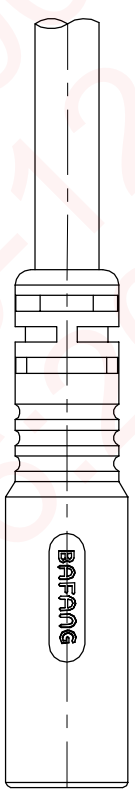
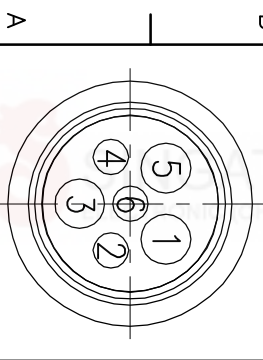

A VIEW

- NOTES:
- ELECTRICAL CHARACTERISTICS:
 - 1-1 CURRENT RATING: (10+2) AMPS.
 - 1-2 CONTACT RESISTANCE: 3 Ohm Max.
 - 1-3 INSULATION RESISTANCE: 30 MOhm Min. at 500VDC.
 - 1-4 BREAKDOWN VOLTAGE: 800 VAC PER MINUTE.
 - ENVIRONMENTAL:
 - 2-1 OPERATING TEMPERATURE: -20°C TO +80°C.
 - 2-2 SEALING REQUIREMENTS: IP65.
 - SPECIFICATIONS: SEE "E-BIKE SERIES SPECIFICATIONS".
 - FOR TECHNICAL DATA REFER TO YOUR LOCAL SINGATRON ELECTRONICS SALES OFFICE.
 - ALL DIMENSIONS ARE NOMINAL FOR REFERENCE ONLY UNLESS OTHERWISE STATED.
 - TO CONFORM TO SINGATRON HAZARDOUS SUBSTANCE FREE SPEC.
 - GREEN PRODUCT IDENTIFICATION LABEL ON PACKAGING:

G	SHRINK TUBE	3	φ1.5mm 300V	BLACK
F	SHRINK TUBE	3	φ2.5mm 600V	BLACK
E	INNER MOLD	1	PVC	BLACK
D	CABLE	1	16#*3C+24#*3C OD6.2	BLACK(PVC JACKET)
C	OVER MOLD	1	HYTREL	BLACK
B	FEMALE PIN	6	Phosphor Bronze	1~3u" GOLD PLATING OVER NICKEL PLATING
A	BODY	1	PA66+30%GF	BLACK
NO	DESCRIPTION	QTY	MATERIAL	PLATING & COLOR

UNLESS OTHERWISE SPECIFIED TOLERANCES

Singatron Enterprise Co., Ltd.
信營企業股份有限公司

DECIMALS:	ANGLES:
X : ±0.5	X : ±2°
X.X : ±0.3	X.X : ±1'
X.XX : ±0.2	

TITLE	E-BIKE SERIES 180° 6 PIN FEMALE CONN.		
DWN	Vicky	PART NO. 2EB3004-W06948H	
CHKD	Harlen	SCALE 2:1	UNIT: mm
APVD	Steve	SIZE: A3	SHEET: 1 OF 1 REV: C

CUSTOMER COPY