

REV.	ECN NO.	OR DESCRIPTION	REVISED	DATE
A	PDR NO.:S140512-5A		Vicky	2014.05.29
B	ECN NO.:S151212-C		Vicky	2016.03.17
C	ECN NO.:S160801-R		Vicky	2016.08.01

文島

DCC(SZ)

10±3

陳環環

2016/08/17

75:40:18

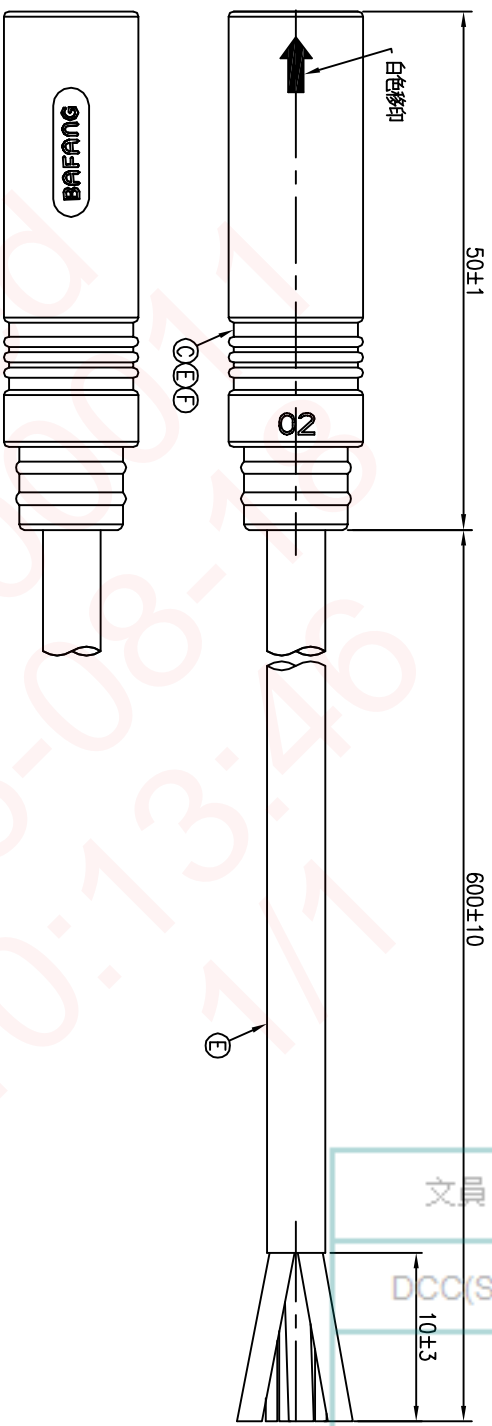
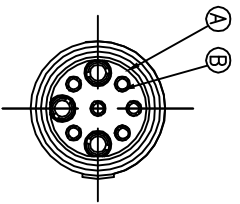

9	BLACK
8	RED
7	BLUE
6	YELLOW
5	GREEN
4	WHITE
3	GREEN(16#)
2	BLUE(16#)
1	YELLOW(16#)
CONN.1 WIRE COLOR	
PIN OUT	

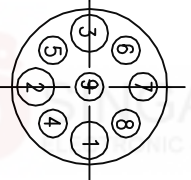

Pin Assignments  
Front View

- NOTES:
1. WATERPROOF RATE: IP65
  2. CURRENT RATING: 10A+5A
  3. CONTACT RESISTANCE: 3 Ohm Max.
  4. HI-POT TEST 800V AC, 5mA(1SEC)
  5. INSULATION RESISTANCE: 30Mohm MIN. BY 500V DC
  6. SPECIFICATIONS:SEE "E-BIKE SERIES SPECIFICATIONS".
  7. TO CONFORM TO THE SINGATRON HAZARDOUS SUBSTANCE FREE SPEC.
  8. GREEN PRODUCT IDENTIFICATION LABEL ON PACKAGING:

F	SHRINK TUBE	6	ø1.5mm 300V	BLACK
E	INNER MOLD	1	PVC	BLACK
D	CABLE	1	16#*3C+24#*6C 0D6.6	BLACK(PVC JACKET)
C	OVER MOLD	1	HYTREL	BLACK
B	FEMALE PIN	9	Phosphor Bronze	1~3u" GOLD PLATING OVER NICKEL PLATING
A	BODY	1	PA66+GF	BLACK
NO	DESCRIPTION		MATERIAL	PLATING & COLOR

UNLESS OTHERWISE SPECIFIED TOLERANCES

DECIMALS: ANGLES:

X :±0.5 X :±2°

X.X :±0.3 X.X :±1°

X.XX :±0.2

Singatron Enterprise Co., Ltd.  
信晉企業股份有限公司

TITLE: E-BIKE SERIES 180' 9 PIN CONN.

DWN: Vicky PART NO.2BB3004-W09710H

CHKD: Harlen SCALE 2:1 UNIT: mm

APVD: Steve SIZE: A3 SHEET:1 OF 1 REV: C

CUSTOMER COPY