

REV	ECN NO	OR DESCRIPTION	REVISED	DATE
A	PDR NO.:S160121-3A	Vicky	2016.01.21	
B	ECN NO.:S160801-R	Vicky	2016.08.01	

胡為南

DCC(SZ)

10±3

2016/08/18

08:52:08

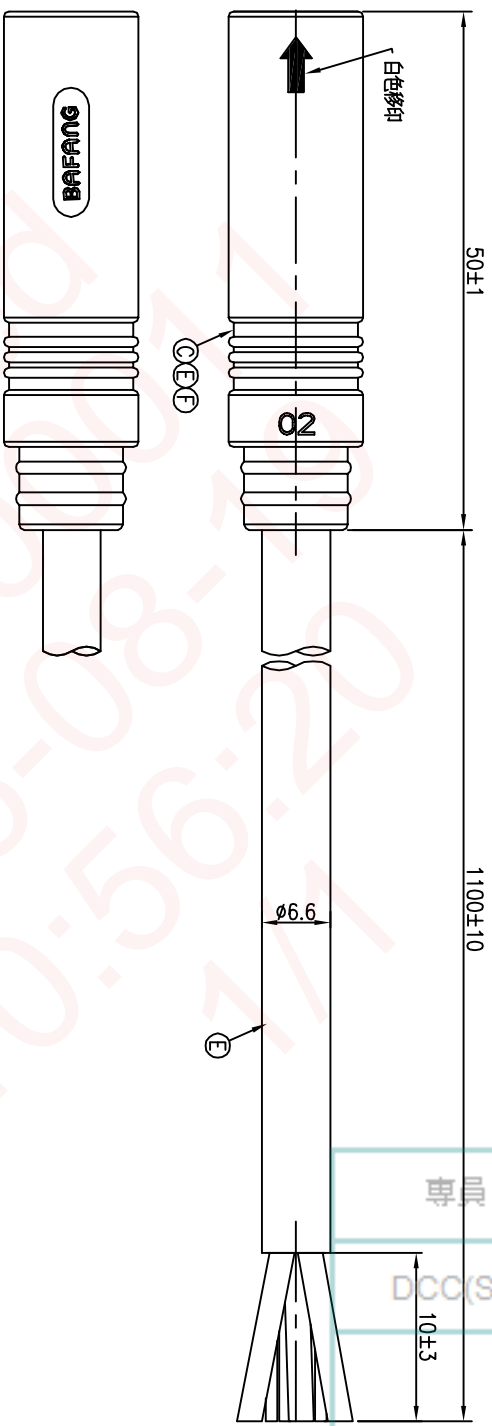
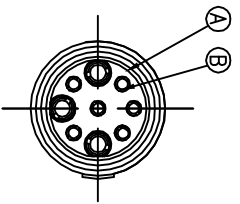

9	BLACK
8	RED
7	BLUE
6	YELLOW
5	GREEN
4	WHITE
3	GREEN(16#)
2	BLUE(16#)
1	YELLOW(16#)
CONN.1 WIRE COLOR	
PIN OUT	

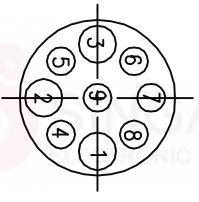

Pin Assignments
Front View

- NOTES:
1. WATERPROOF RATE: IP65
 2. CURRENT RATING: 10A+5A
 3. CONTACT RESISTANCE: 3 Ohm Max.
 4. HI-POT TEST 800V AC, 5mA(1SEC)
 5. INSULATION RESISTANCE: 30Mohm MIN. BY 500V DC
 6. SPECIFICATIONS:SEE "E-BIKE SERIES SPECIFICATIONS".
 7. TO CONFORM TO THE SINGATRON HAZARDOUS SUBSTANCE FREE SPEC.
 8. GREEN PRODUCT IDENTIFICATION LABEL ON PACKAGING:

NO	DESCRIPTION	QTY	MATERIAL	PLATING & COLOR
A	BODY	1	PA66+GF	BLACK
B	FEMALE PIN	9	Phosphor Bronze	1~3u" GOLD PLATING OVER NICKEL PLATING
C	OVER MOLD	1	HYTREL	BLACK
D	CABLE	1	16#*3C+24#*6C	0D6.6 BLACK(PVC JACKET)
E	INNER MOLD	1	PVC	BLACK
F	SHRINK TUBE	6	ø1.5mm 300V	BLACK
G	SHRINK TUBE	3	ø2.5mm 300V	BLACK

DECIMALS:	ANGLES:	TITLE
X :±0.5	X :±2°	E-BIKE SERIES 180' 9 PIN CONN.
X.X :±0.3	X.X :±1°	
X.XX :±0.2		

Singatron Enterprise Co., Ltd.
 信晉企業股份有限公司

PART NO.2BB3004-W09737H
 SCALE 2:1 UNIT: mm
 SIZE: A3 SHEET:1 OF 1 REV: B
 CUSTOMER COPY