

REV.	ECN NO.	OR DESCRIPTION	REVISED	DATE
A	PDR NO.:S160419-3A/3B	Vicky		2016.4.19
B	ECN NO.:S160801-R	Vicky		2016.08.01

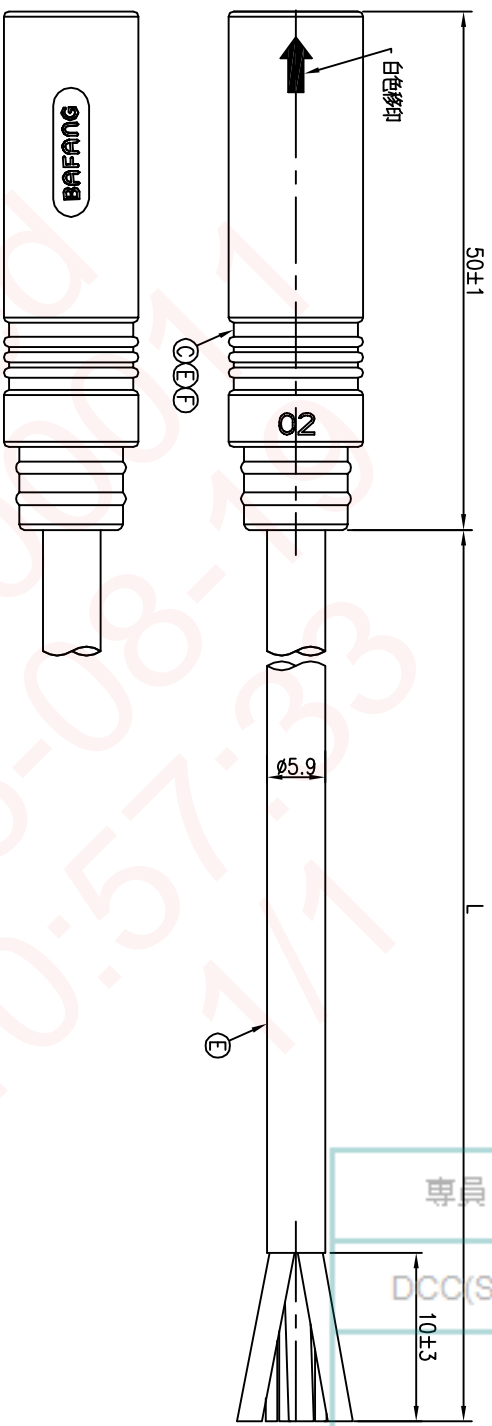

9	BLACK
8	RED
7	BLUE
6	YELLOW
5	GREEN
4	WHITE
3	GREEN(16#)
2	BLUE(16#)
1	YELLOW(16#)
CONN.1 WIRE COLOR	
PIN OUT	

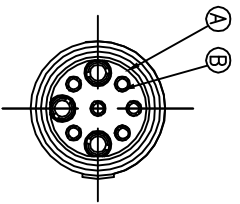
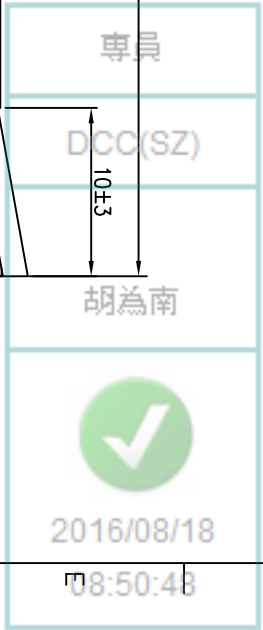
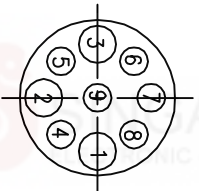

Pin Assignments  
Front View

- NOTES:
1. WATERPROOF RATE: IP65
  2. CURRENT RATING: 10A+5A
  3. CONTACT RESISTANCE: 3 Ohm Max.
  4. HI-POT TEST 800V AC, 5mA(1SEC)
  5. INSULATION RESISTANCE: 30Mohm MIN. BY 500V DC
  6. SPECIFICATIONS:SEE "E-BIKE SERIES SPECIFICATIONS".
  7. TO CONFORM TO THE SINGATRON HAZARDOUS SUBSTANCE FREE SPEC.
  8. GREEN PRODUCT IDENTIFICATION LABEL ON PACKAGING:

F	SHRINK TUBE	6	φ1.5mm 300V	BLACK
E	INNER MOLD	1	PVC	BLACK
D	CABLE	1	16#*3C+24#*6C 0D5.9	BLACK(PVC JACKET)
C	OVER MOLD	1	HYTREL	BLACK
B	FEMALE PIN	9	Phosphor Bronze	1~3u" GOLD PLATING OVER NICKEL PLATING
A	BODY	1	PA66+GF	BLACK

NO	DESCRIPTION	QTY	MATERIAL	PLATING & COLOR
UNLESS OTHERWISE SPECIFIED TOLERANCES				
DECIMALS: ANGLES:				
X	:±0.5	X	:±2°	
X.X	:±0.3	X.X	:±1°	
X.XX	:±0.2			
Singatron Enterprise Co., Ltd. 信晉企業股份有限公司				
TITLE: E-BIKE SERIES 180' 9 PIN CONN.				
DWN	Vicky	PART NO.2EB3004-W09740H~41H		
CHKD	Harten	SCALE: 2:1	UNIT: mm	
APVD	Steve	SIZE: A3	SHEET:1 OF 1	REV: B

CUSTOMER COPY