

REV.	ECN NO.	OR DESCRIPTION	REVISED	DATE
A	PDR NO.:	S160920-1B	Vicky	2016.09.20

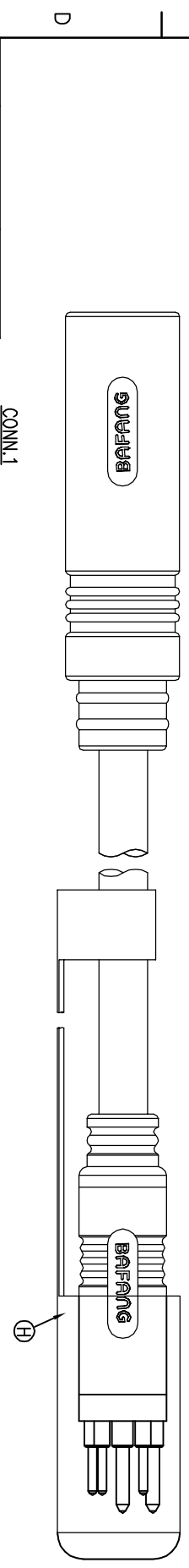

9	BLACK	9
8	RED	8
7	BLUE	7
6	YELLOW	6
5	GREEN	5
4	WHITE	4
3	GREEN(16#)	3
2	BLUE(16#)	2
1	YELLOW(16#)	1
CONN.1 WIRE COLOR		CONN.2
PIN OUT		

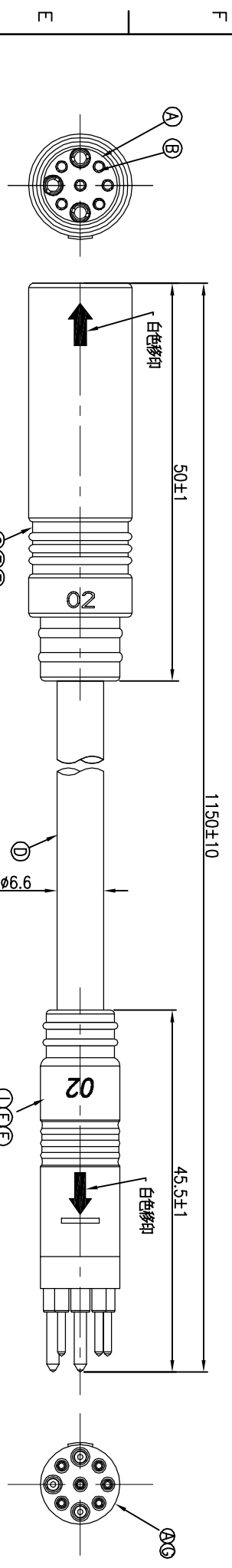
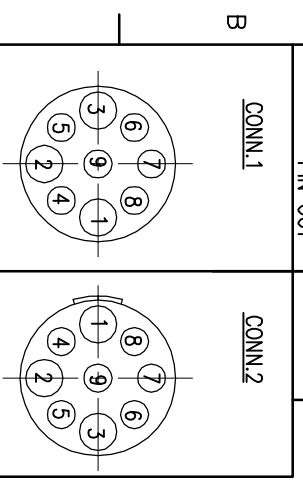

Pin Assignments
Front View

- NOTES:
1. WATERPROOF RATE: IP65
 2. CURRENT RATING: 10A+5A
 3. CONTACT RESISTANCE: 3 Ohm Max.
 4. HI-POT TEST 800V AC, 5mA(1SEC)
 5. INSULATION RESISTANCE: 30Mohm MIN. BY 500V DC
 6. SPECIFICATIONS:SEE "E-BIKE SERIES SPECIFICATIONS".
 7. TO CONFORM TO THE SINGATRON HAZARDOUS SUBSTANCE FREE SPEC.
 8. GREEN PRODUCT IDENTIFICATION LABEL ON PACKAGING:

I	OVER MOLD	1	TPU	BLACK
H	CAP	1	NYLON	NATURAL
G	MALE PIN	9	BRASS	1~3u" GOLD PLATING OVER NICKEL PLATING
F	SHRINK TUBE	12	Ø1.5mm 300V	BLACK
E	INNER MOLD	2	PVC	BLACK
D	CABLE	1	16#*3C+24#*6C OD6.6	BLACK(PVC JACKET)
C	OVER MOLD	1	HYTREL	BLACK
B	FEMALE PIN	9	Phosphor Bronze	1~3u" GOLD PLATING OVER NICKEL PLATING
A	BODY	2	PA66+GF	BLACK

NO	DESCRIPTION	QTY	MATERIAL	PLATING & COLOR
UNLESS OTHERWISE SPECIFIED TOLERANCES				
Singatron Enterprise Co., Ltd. 信言企业股份有限公司				
TITLE E-BIKE SERIES 180" 9 PIN CONN.				
DWN	Vicky	PART NO.2EB3004-W0975IH		
CHKD	Horlen	SCALE 2:1	UNIT: mm	
APVD	Steve	SIZE: A3	SHEET: 1 OF 1	REV: A

DECIMALS:	ANGLES:
X :±0.5	X :±2°
X.X :±0.3	X.X :±1'
X.XX :±0.2	

CUSTOMER COPY