

| REV. | ECN NO. | OR DESCRIPTION | REVISED | DATE |
|------|----------|----------------|---------|------------|
| A | PDR NO.: | S170605-7A | Vicky | 2017.06.05 |

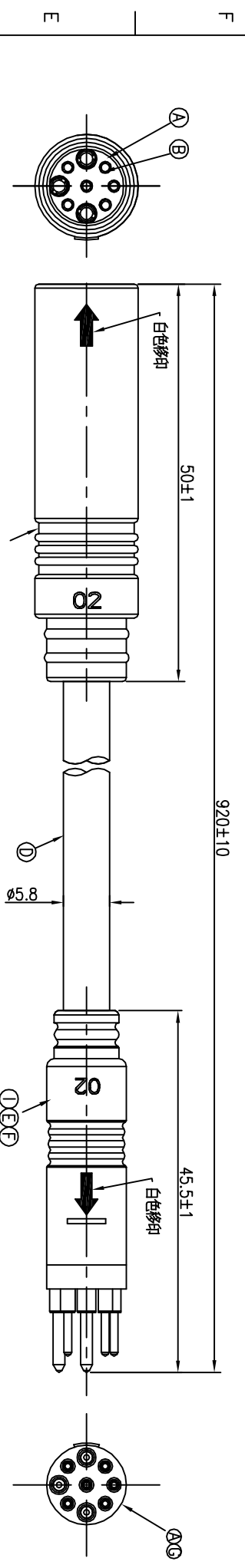

| | | |
|-------------------|-------------|--------|
| 9 | BLACK | 9 |
| 8 | RED | 8 |
| 7 | BLUE | 7 |
| 6 | YELLOW | 6 |
| 5 | GREEN | 5 |
| 4 | WHITE | 4 |
| 3 | GREEN(16#) | 3 |
| 2 | BLUE(16#) | 2 |
| 1 | YELLOW(16#) | 1 |
| CONN.1 WIRE COLOR | | CONN.2 |
| PIN OUT | | |

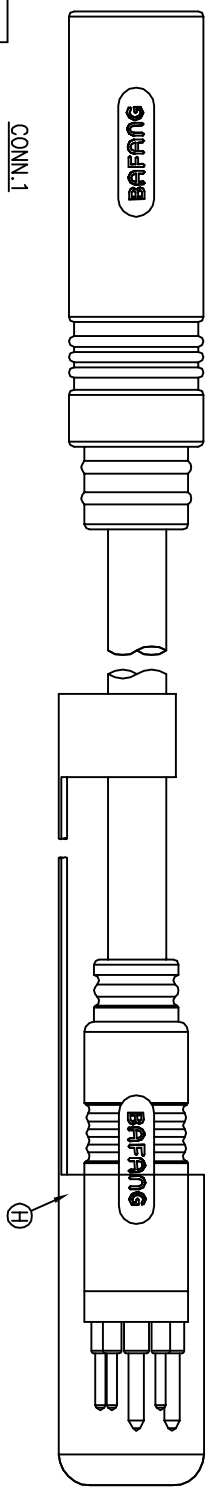
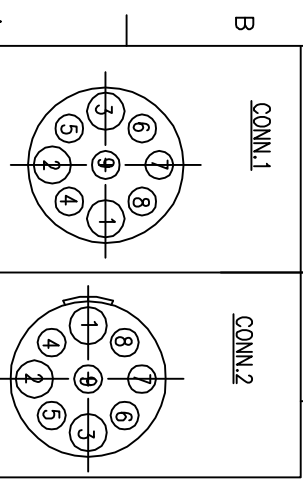

| | | | | |
|----|-------------|-----|-------------------|--|
| I | OVER MOLD | 1 | TPU | BLACK |
| H | CAP | 1 | NYLON | NATURAL |
| G | MALE PIN | 9 | BRASS | 1~3u" GOLD PLATING OVER NICKEL PLATING |
| F | SHRINK TUBE | 12 | ∅1.5mm 300V | BLACK |
| E | INNER MOLD | 2 | PVC | BLACK |
| D | CABLE | 1 | 1.2mm*3C+0.2mm*3C | BLACK(PVC JACKET) |
| C | OVER MOLD | 1 | HYTREL | BLACK |
| B | FEMALE PIN | 9 | Phosphor Bronze | 1~3u" GOLD PLATING OVER NICKEL PLATING |
| A | BODY | 2 | PA66+GF | BLACK |
| NO | DESCRIPTION | QTY | MATERIAL | PLATING & COLOR |

- NOTES:
1. WATERPROOF RATE: IP65
 2. CURRENT RATING: 10A+5A
 3. CONTACT RESISTANCE: 3 Ohm Max.
 4. HI-POT TEST 800V AC, 5mA(1SEC)
 5. INSULATION RESISTANCE: 30Mohm MIN. BY 500V DC
 6. SPECIFICATIONS:SEE "E-BIKE SERIES SPECIFICATIONS".
 7. TO CONFORM TO THE SINGATRON HAZARDOUS SUBSTANCE FREE SPEC.
 8. GREEN PRODUCT IDENTIFICATION LABEL ON PACKAGING:

| | | | |
|---------------------------------------|----------|--|--|
| UNLESS OTHERWISE SPECIFIED TOLERANCES | | SINGATRON ENTERPRISE CO., LTD. | |
| DECIMALS: | ANGLES: | 信晉企業股份有限公司 | |
| X :±0.5 | X :±2° | TITLE E-BIKE SERIES 180° 9 PIN CONN. | |
| X.X :±0.3 | X.X :±1° | DWG Vicky PART NO.2EB3004-W09783H | |
| X.XX :±0.2 | | CHKD Horlen SCALE 2:1 UNIT: mm | |
| | | APVD Steve SIZE: A3 SHEET: 1 OF 1 REV: A | |

CUSTOMER COPY