

REV.	ECN NO.	OR DESCRIPTION	REVISED	DATE
A	PDR NO.:	S160817-5A	Vicky	2016.08.17

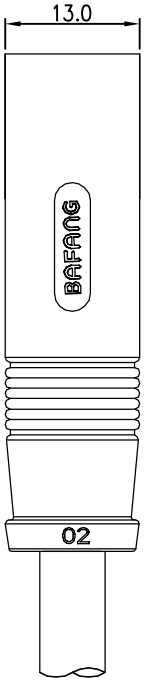

9	BLACK
8	RED
7	BLUE
6	YELLOW
5	GREEN
4	WHITE
3	GREEN(1.2 ²)
2	BLUE(1.2 ²)
1	YELLOW(1.2 ²)
CONN.1 WIRE COLOR	
PIN OUT	

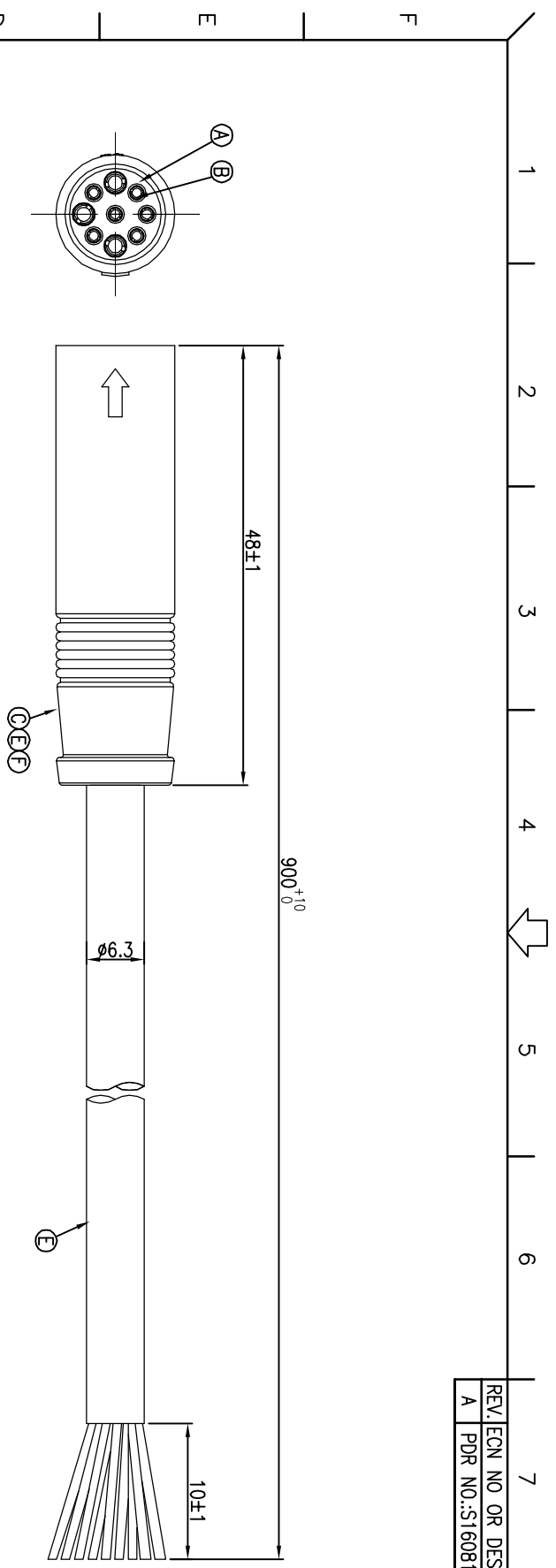
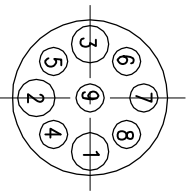

Pin Assignments
Front View

- NOTES:
1. WATERPROOF RATE: IP65
 2. CURRENT RATING: 10A+5A
 3. CONTACT RESISTANCE: 3 Ohm Max.
 4. HI-POT TEST 800V AC, 5mA(1SEC)
 5. INSULATION RESISTANCE: 30Mohm MIN. BY 500V DC
 6. SPECIFICATIONS:SEE "E-BIKE SERIES SPECIFICATIONS".
 7. TO CONFORM TO THE SINGATRON HAZARDOUS SUBSTANCE FREE SPEC.
 8. GREEN PRODUCT IDENTIFICATION LABEL ON PACKAGING:

F	SHRINK TUBE	6	φ1.5mm 300V	BLACK
E	INNER MOLD	1	PVC	BLACK
D	CABLE	1	1.2*3C+0.2*6C OD6.3	BLACK(PVC JACKET)
C	OVER MOLD	1	HYTREL	BLACK
B	FEMALE PIN	9	Phosphor Bronze	1~3u" GOLD PLATING OVER NICKEL PLATING
A	BODY	1	PA66+GF	BLACK

UNLESS OTHERWISE SPECIFIED TOLERANCES

NO	DESCRIPTION	QTY	MATERIAL	PLATING & COLOR
A	BODY	1	PA66+GF	BLACK

DECIMALS: ANGLES:

X	:±0.5	X	:±2°
X.X	:±0.3	X.X	:±1°
X.XX	:±0.2		

Singatron Enterprise Co., Ltd.
信譽企業股份有限公司

TITLE E-BIKE SERIES 180" 9 PIN CONN.

DWN	Vicky	PART NO.2EB3004-W097A2H	UNIT: mm	
CHKD	Harlan	SCALE 2:1	UNIT: mm	
APVD	Steve	SIZE: A3	SHEET: 1 OF 1	REV: A

CUSTOMER COPY