

REV.	ECN NO.	OR DESCRIPTION	REVISED	DATE
A	PDR NO:S131227-1H		Horlen	2013.12.20

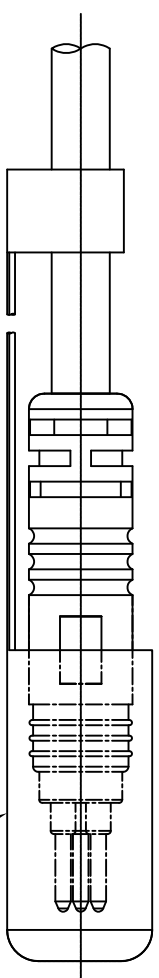

3	RED
2	BLACK
1	/
CONN. WIRE COLOR	
PIN OUT	
CONN.	

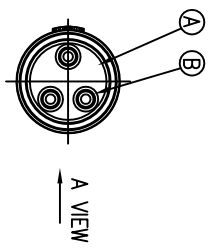
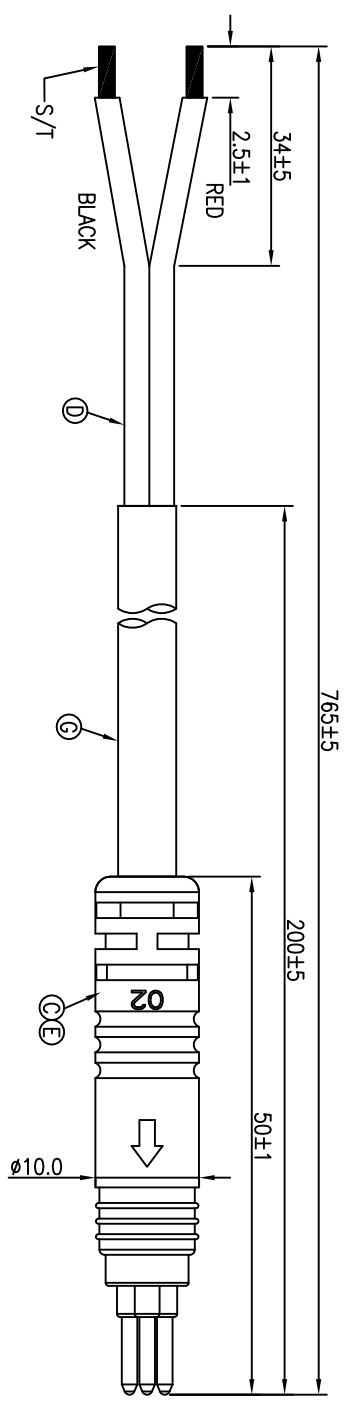
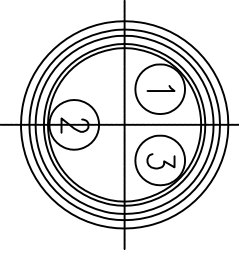

Pin Assignments
Front View

NOTES:

1. WATERPROOF RATE: IP65
2. CURRENT RATING: 10A
3. CONTACT RESISTANCE: 3 Ohm Max.
4. HI-POT TEST 800V AC, 5mA(1SEC)
5. INSULATION RESISTANCE: 30Mohm MIN. BY 500V DC
6. TO CONFORM TO THE SINGATRON HAZARDOUS SUBSTANCE FREE SPEC.
7. GREEN PRODUCT IDENTIFICATION LABEL ON PACKAGING: [C.R. 2145]
8. ALL PRODUCTS MEET THE ROHS COMPLIANT.
9. REFER TO FARADAY PART NO.305-0021-A.

NO	DESCRIPTION	QTY	MATERIAL	PLATING & COLOR
A	BODY	1	PA66+GF	BLACK
B	MALE PIN	3	BRASS	GOLD PLATING
UNLESS OTHERWISE SPECIFIED TOLERANCES				
G	SHRINK TUBE	1	1/4-DR-25 RANCHEN	BLACK
F	CAP	1	PA66	NATURAL
E	INNER MOLD	1	ABS	NATURAL
D	CABLE	1	16#*2C	BLACK&RED
C	OVER MOLD	1	TPU	BLACK

DECIMALS:	ANGLES:	TITLE	SINGATRON ENTERPRISE CO., LTD.	
X :±0.5	X :±2°	E-BIKE SERIES 180° 3 PIN MALE CONN.	信登企業股份有限公司	
X.X :±0.3	X.X :±1'			
X.XX :±0.2				
CUSTOMER COPY				