

REV.	ECN NO.	OR DESCRIPTION	REVISED	DATE
A	ECN NO.A181001-0		Vckv	2018.10.23

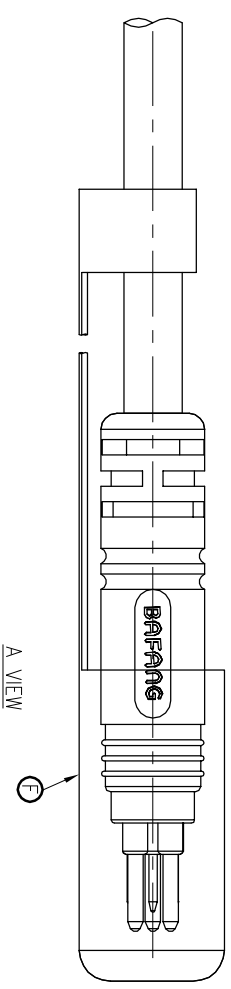

6	BLACK
5	YELLOW
4	WHITE
3	BLUE
2	RED
1	GREEN
CONN. WIRE COLOR	
PIN OUT	
CONN.	

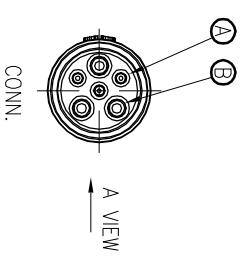
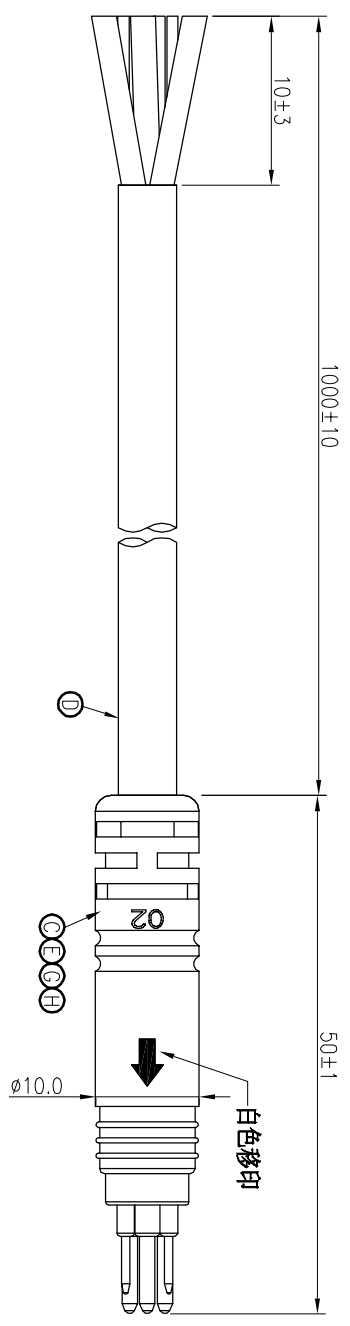
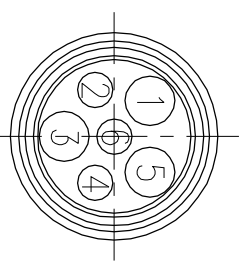

Pin Assignments
Front View

- NOTES:
1. WATERPROOF RATE: IP65
 2. CURRENT RATING: 10A+2A
 3. CONTACT RESISTANCE: 3 Ohm Max.
 4. HI-POT TEST 800V AC, 5mA(1SEC)
 5. INSULATION RESISTANCE: 30Mohm MIN. BY 500V DC
 6. SPECIFICATIONS:SEE "E-BIKE SERIES SPECIFICATIONS".
 7. TO CONFORM TO THE SINGATRON HAZARDOUS SUBSTANCE FREE SPEC.
 8. GREEN PRODUCT IDENTIFICATION LABEL ON PACKAGING:

G	SHRINK TUBE	3	Ø1.5mm 300V	BLACK
F	CAP	1	PA66	NATURAL
E	INNER MOLD	1	ABS	NATURAL
D	CABLE	1	16#*3C+24#*3C. OD5.6	BLACK(PVC JACKET)
C	OVER MOLD	1	TPU	BLACK
B	MALE PIN	6	BRASS	1~3μ" GOLD PLATING OVER NICKEL PLATING
A	BODY	1	PA66+30%GF	BLACK
NO DESCRIPTION		QTY	MATERIAL	PLATING & COLOR
UNLESS OTHERWISE SPECIFIED TOLERANCES				
Singatron Enterprise Co., Ltd. 信譽企業股份有限公司				
TITLE E-BIKE SERIES 180° 6 PIN MALE CONN.				
DECIMALS:	ANGLES:			
X :±0.5	X :±2°			
X.X :±0.3	X.X :±1°			
X.XX :±0.2				
CUSTOMER COPY				