

REV.	ECN NO.	OR DESCRIPTION	REVISED	DATE
A	PDR NO.:	S160323-5B	Wcky	2016.03.23
B	ECN NO.:	S160801-R	Wcky	2016.08.01

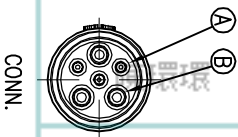

2016/08/15

6	BLACK
5	YELLOW
4	WHITE
3	BLUE
2	RED
1	GREEN
CONN. WIRE COLOR	
PIN OUT	
CONN.	

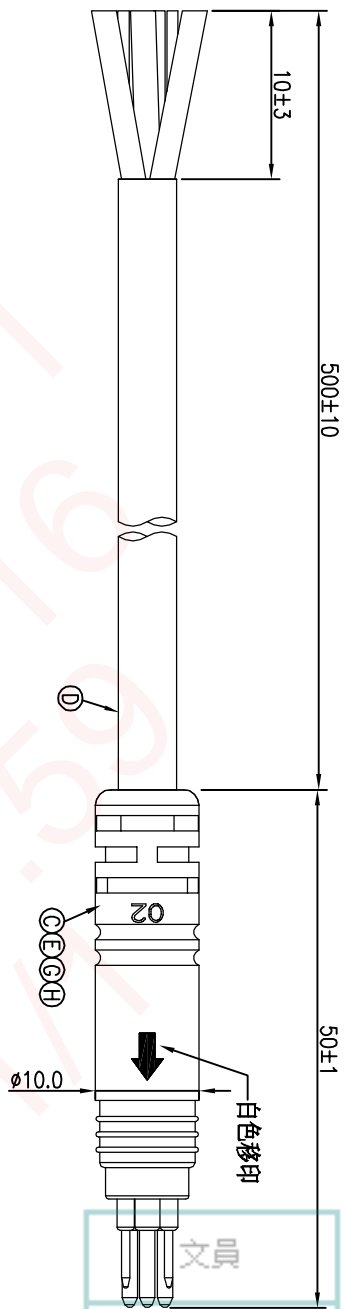
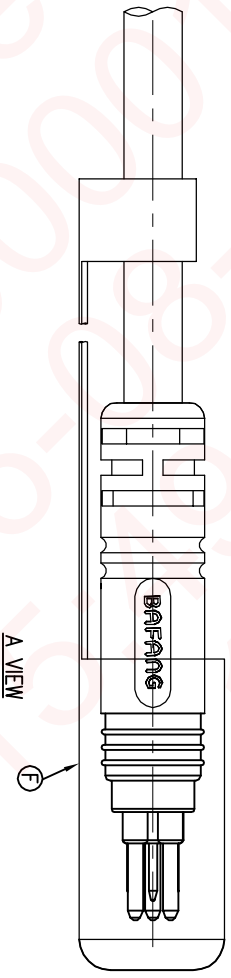
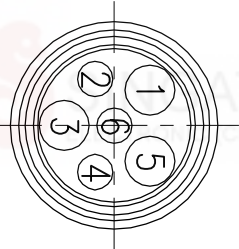

- NOTES:
1. WATERPROOF RATE: IP65
 2. CURRENT RATING: 10A+2A
 3. CONTACT RESISTANCE: 3 Ohm Max.
 4. HI-POT TEST 800V AC, 5mA(1SEC)
 5. INSULATION RESISTANCE: 30Mohm MIN. BY 500V DC
 6. SPECIFICATIONS:SEE "E-BIKE SERIES SPECIFICATIONS".
 7. TO CONFORM TO THE SINGATRON HAZARDOUS SUBSTANCE FREE SPEC.
 8. GREEN PRODUCT IDENTIFICATION LABEL ON PACKAGING:

NO	DESCRIPTION	QTY	MATERIAL	PLATING & COLOR
A	BODY	1	PA66+30%GF	BLACK
B	MALE PIN	6	BRASS	1~3μ" GOLD PLATING OVER NICKEL PLATING
C	OVER MOLD	1	TPU	BLACK
D	CABLE	1	16#*3C+24#*3C OD5.6	BLACK(PVC JACKET)
E	INNER MOLD	1	ABS	NATURAL
F	CAP	1	PA66	NATURAL
G	SHRINK TUBE	3	φ1.5mm 300V	BLACK

UNLESS OTHERWISE SPECIFIED TOLERANCES

Singatron Enterprise Co., Ltd.
信譽企業股份有限公司

DECIMALS:	ANGLES:
X :±0.5	X :±2°
X.X :±0.3	X.X :±1'
X.XX :±0.2	

TITLE: E-BIKE SERIES 180° 6 PIN MALE CONN.
DWG: Wcky PART NO. 2EB3024-M06910H
CHKD: Harden SCALE 2:1 UNIT: mm
APVD: Steve SIZE: A3 SHEET: 1 OF 1 REV: B

CUSTOMER COPY

