

REV.	ECN NO. OR DESCRIPTION	REVISED	DATE
A	PDR NO.:T1150326-3B	Wcky	2015.03.30

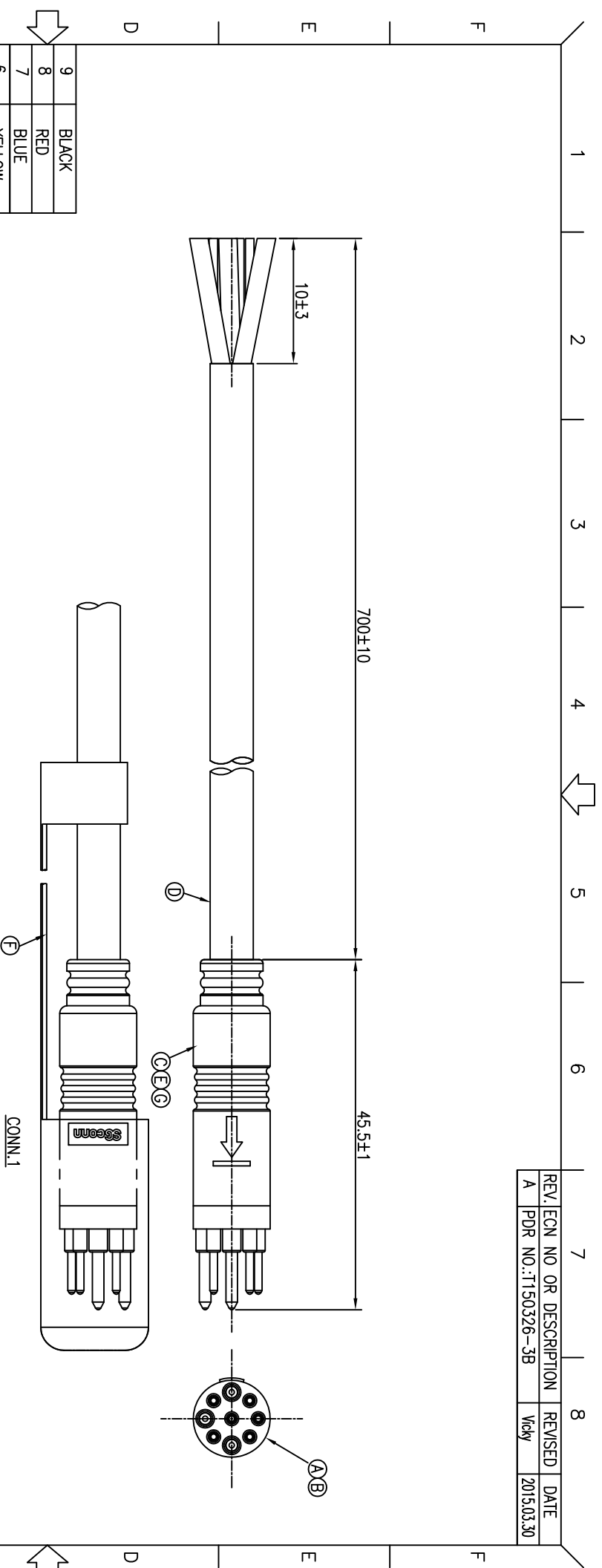

9	BLACK
8	RED
7	BLUE
6	YELLOW
5	GREEN
4	WHITE
3	GREEN(16#)
2	BLUE(16#)
1	YELLOW(16#)
CONN.1 WIRE COLOR	
PIN OUT	

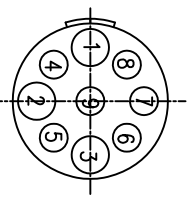

Pin Assignments  
Front View

- NOTES:
1. WATERPROOF RATE: IP65
  2. CURRENT RATING: 10A+5A
  3. CONTACT RESISTANCE: 3 Ohm Max.
  4. HI-POT TEST 800V AC, 5mA(1SEC)
  5. INSULATION RESISTANCE: 30Mohm MIN. BY 500V DC
  6. SPECIFICATIONS:SEE "E-BIKE SERIES SPECIFICATIONS."
  7. TO CONFORM TO THE SINGATRON HAZARDOUS SUBSTANCE FREE SPEC.
  8. GREEN PRODUCT IDENTIFICATION LABEL ON PACKAGING:

G	SHRINK TUBE	6	ø1.5mm 300V	BLACK
F	CAP	1	NYLON	WHITE
E	INNER MOLD	1	PVC 30P	NATURAL
D	CABLE	1	16#*3C+24#*6C OD5.8	BLACK(PVC JACKET)
C	OVER MOLD	1	TPU	BLACK
B	MALE PIN	9	BRASS	1-~3u" GOLD PLATING OVER NICKEL PLATING
A	BODY	1	PA66+GF	BLACK
NO	DESCRIPTION	QTY	MATERIAL	PLATING & COLOR

UNLESS OTHERWISE SPECIFIED TOLERANCES

Singatron Enterprise Co., Ltd.  
信營企業股份有限公司

DECIMALS:	ANGLES:	TITLE	E-BIKE SERIES 180' 9 PIN CONN.
X :±0.5	X :±2'	DWN	Wcky
X.X :±0.3	X.X :±1'	CHKD	Harten
X:XX :±0.2		APVD	Steve

PART NO.2BB3024-W09705H  
SCALE 2:1 UNIT: mm  
SIZE: A3 SHEET:1 OF 1 REV: A

CUSTOMER COPY