

P/N LEGEND

2FF0526	WRC-S-XP	N	L	X	XX	T	00	R
①	②	③	④	⑤	⑥	⑦	⑧	⑨

① Series No.
 ② Connector type: WRC=Right Angle
 ③ S=SMT
 ④ No. of circuits
 ⑤ N=Halogen Free
 ⑥ Material: L=LCP
 ⑦ Color: N=Natural, B=Black
 ⑧ Plating code for contacts: G1=Gold-flash 1u" (鍍金)
 K4=Gold-plater 10u" on contact area, NiCeI-plated on solder area
 ⑨ Plating code: T=Tin-Plated
 ⑩ Option code: 00=Standard
 ⑪ Packing code: R=Tape Reel(Without Cap or Mylar)

SPECIFICATIONS

Current Rating: 0.5A AC,DC
 Voltage Rating: 50V AC,DC
 Temperature Range: -55°C ~ +85°C
 Pin Material: Phosphor Bronze
 Solder Tabs: Phosphor Bronze

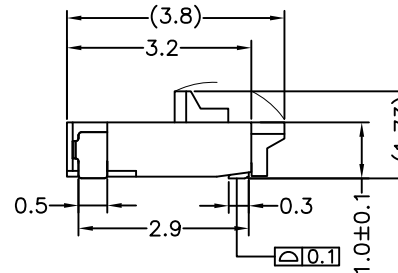
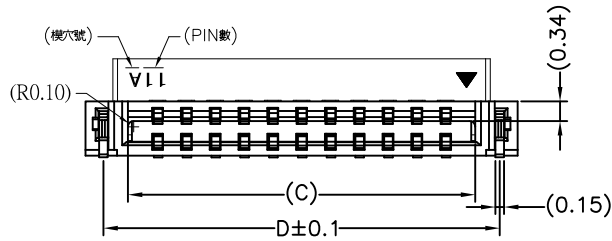

Circuit No.	Dimensions				Circuit No.	Dimensions			
	A	B	C	D		A	B	C	D
04P	4.0	1.5	2.53	3.38	19P	11.5	9.0	10.07	10.88
05P	4.5	2.0	3.03	3.88	20P	12.0	9.5	10.57	11.38
06P	5.0	2.5	3.53	4.38	21P	12.5	10.0	11.07	11.88
07P	5.5	3.0	4.03	4.88	22P	13.0	10.5	11.57	12.38
08P	6.0	3.5	4.53	5.38	23P	13.5	11.0	12.07	12.88
09P	6.5	4.0	5.03	5.88	24P	14.0	11.5	12.57	13.38
10P	7.0	4.5	5.53	6.38	25P	14.5	12.0	13.07	13.88
11P	7.5	5.0	6.03	6.88	26P	15.0	12.5	13.57	14.38
12P	8.0	5.5	6.53	7.38	27P	15.5	13.0	14.07	14.88
13P	8.5	6.0	7.03	7.88	28P	16.0	13.5	14.57	15.38
14P	9.0	6.5	7.53	8.38	29P	16.5	14.0	15.07	15.88
15P	9.5	7.0	8.03	8.88	30P	17.0	14.5	15.57	16.38
16P	10.0	7.5	8.53	9.38	31P	17.5	15.0	16.07	16.88
17P	10.5	8.0	9.03	9.88	32P	18.0	15.5	16.57	17.38
18P	11.0	8.5	9.53	10.38					

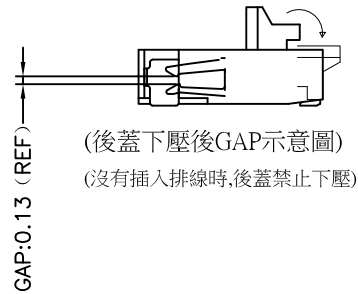
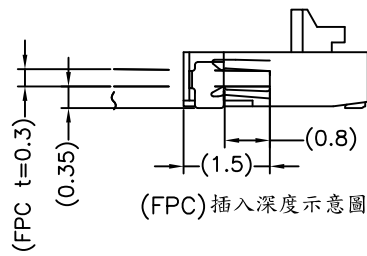

REV.	DESCRIPTION	DATE	NAME
A3	EN20210520648	2021.05.25	吳清
A2	EN20200605302	2020.06.05	劉建芳
A1	EN1901170001	2019.01.22	徐富永
A0	NEW RELEASE	2018.10.15	徐富永

GENERAL TOLERANCE
 X. X±0.25
 X. XX±0.15
 X. XXX±0.05

Singatron Enterprise Co., Ltd.			
TITLE	0.50mm PITCH 1.0H FPC CONN.		
DWN	徐富永	PART NO.	2FF0526WRC-S-XPXXXXXXX
CHKD	2018.05.28	SCALE 1:1	UNIT: mm
APVD	謝瑞清	SIZE: A3	SHEET: 1 OF 3 REV: A3
CUSTOMER COPY			



Recommended metal mask thickness: $t=0.1\text{mm}$
TOP VIEW

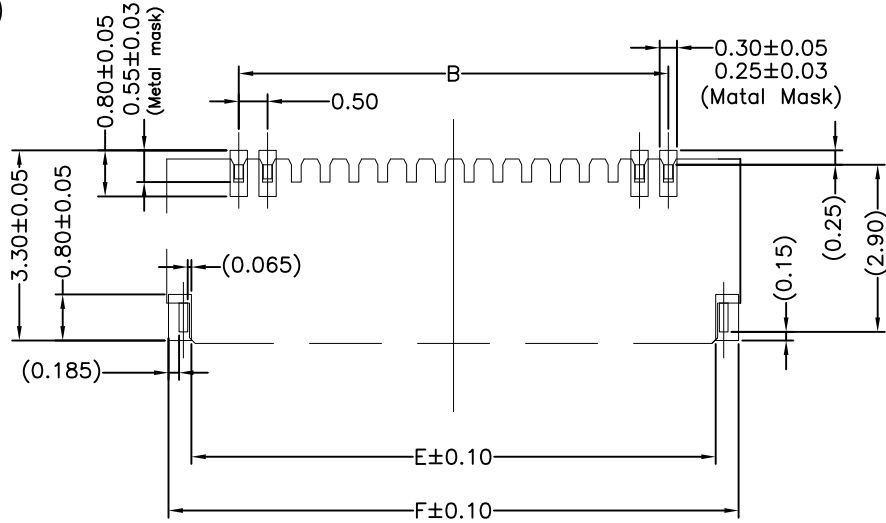

Recommended FPC

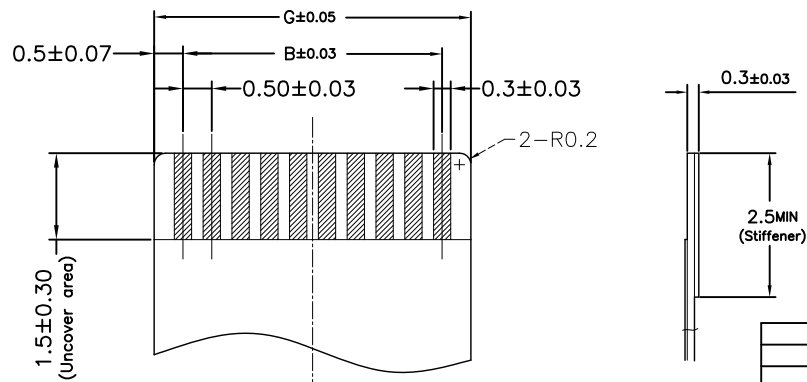

Circuit No.	Dimensions				Circuit No.	Dimensions			
	B	E	F	G		B	E	F	G
04P	1.5	3.1	3.9	2.5	19P	9.0	10.6	11.4	10.0
05P	2.0	3.6	4.4	3.0	20P	9.5	11.1	11.9	10.5
06P	2.5	4.1	4.9	3.5	21P	10.0	11.6	12.4	11.0
07P	3.0	4.6	5.4	4.0	22P	10.5	12.1	12.9	11.5
08P	3.5	5.1	5.9	4.5	23P	11.0	12.6	13.4	12.0
09P	4.0	5.6	6.4	5.0	24P	11.5	13.1	13.9	12.5
10P	4.5	6.1	6.9	5.5	25P	12.0	13.6	14.4	13.0
11P	5.0	6.6	7.4	6.0	26P	12.5	14.1	14.9	13.5
12P	5.5	7.1	7.9	6.5	27P	13.0	14.6	15.4	14.0
13P	6.0	7.6	8.4	7.0	28P	13.5	15.1	15.9	14.5
14P	6.5	8.1	8.9	7.5	29P	14.0	15.6	16.4	15.0
15P	7.0	8.6	9.4	8.0	30P	14.5	16.1	16.9	15.5
16P	7.5	9.1	9.9	8.5	31P	15.0	16.6	17.4	16.0
17P	8.0	9.6	10.4	9.0	32P	15.5	17.1	17.9	16.5
18P	8.5	10.1	10.9	9.5					

A3	EN20210520648	2021.05.25	吳清	
A2	EN20200605302	2020.06.05	劉建芳	GENERAL TOLERANCE
A1	EN1901170001	2019.01.22	徐富永	X.X±0.25
A0	NEW RELEASE	2018.10.15	徐富永	X.XX±0.15
REV.	DESCRIPTION	DATE	NAME	X.XXX±0.05

Singatron Enterprise Co., Ltd.				
TITLE	0.50mm PITCH 1.0H FPC CONN.			
DWN	徐富永	PART NO.	2FF0526WRC-S-XPXXXXXXX	
CHKD	2018.05.28	SCALE 1:1	UNIT: mm	
APVD	謝瑞清	SIZE: A3	SHEET: 2 OF 3	REV: A3
CUSTOMER COPY				



04~27 Contacts

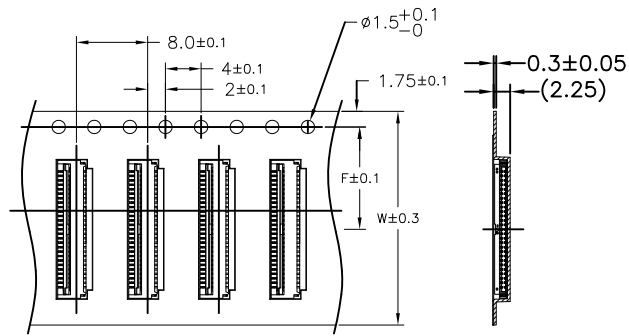

28~32 Contacts

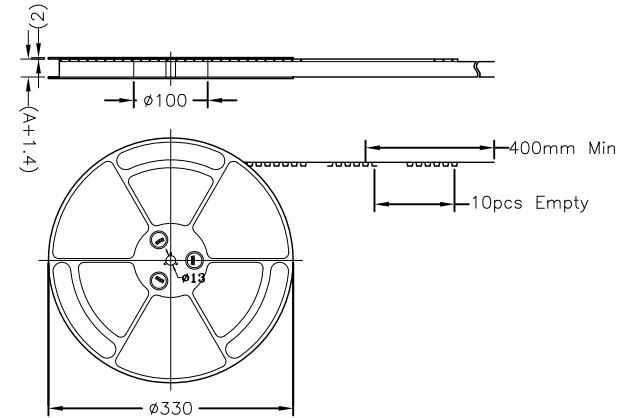
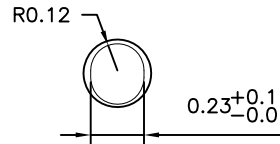
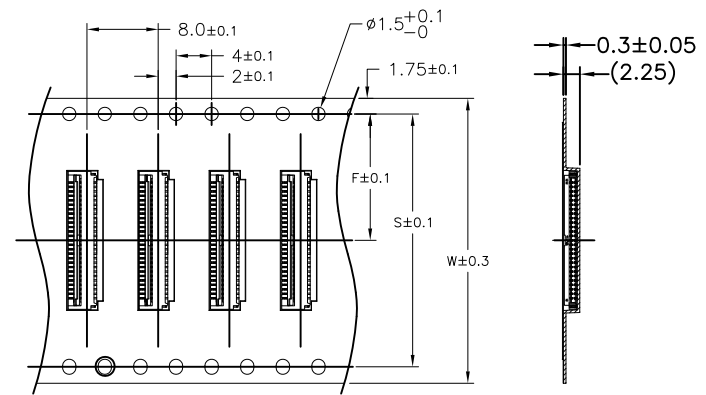

Notes:

1. Material : Black Conductive Polystyrene Alloy.
2. All dimensions meet EIA-481-C requirements.

Number of Contacts	W±0.3	F±0.1	S±0.1	Q'ty/Reel	Number of Contacts	W±0.3	F±0.1	S±0.1	Q'ty/Reel
4P	16	7.5		4,000	19P	24	11.5		4,000
5P	16	7.5		4,000	20P	24	11.5		4,000
6P	16	7.5		4,000	21P	24	11.5		4,000
7P	16	7.5		4,000	22P	24	11.5		4,000
8P	16	7.5		4,000	23P	24	11.5		4,000
9P	16	7.5		4,000	24P	24	11.5		4,000
10P	16	7.5		4,000	25P	24	11.5		4,000
11P	16	7.5		4,000	26P	24	11.5		4,000
12P	24	11.5		4,000	27P	24	11.5		4,000
13P	24	11.5		4,000	28P	32	14.2	28.4	4,000
14P	24	11.5		4,000	29P	32	14.2	28.4	4,000
15P	24	11.5		4,000	30P	32	14.2	28.4	4,000
16P	24	11.5		4,000	31P	32	14.2	28.4	4,000
17P	24	11.5		4,000	32P	32	14.2	28.4	4,000
18P	24	11.5		4,000					

REV.	DESCRIPTION	DATE	NAME
A3	EN20210520648	2021.05.25	吳清
A2	EN20200605302	2020.06.05	劉建芳
A1	EN1901170001	2019.01.22	徐富永
A0	NEW RELEASE	2018.10.15	徐富永

GENERAL TOLERANCE	
X.X±0.25	
X.XX±0.15	
X.XXX±0.05	

Singatron Enterprise Co., Ltd.				
TITLE	0.50mm PITCH 1.0H FPC CONN.			
DWN	徐富永	PART NO.	2FF0526WRC-S-XPXXXXXXX	
CHKD	2018.05.28	SCALE 1:1	UNIT: mm	⊕ ↻
APVD	謝瑞清	SIZE: A3	SHEET: 3 OF 3	REV: A3
CUSTOMER COPY				