

HF RoHS COMPLIANT PRODUCT

NOTE:

1.MATERIAL:

HOUSING: LCP(UL94V-0)
 ACTUATOR: LCP(UL94V-0)
 TERMINAL: PHOSPHOR BRONZE
 SOLDER PAD: BRASS

2.PLATING:

TERMINAL: GOLD OVER NICKEL
 SOLDER PAD: TIN OVER NICKEL

3.PART NO.:

2FFBL309-xxS22-TAHO

SERIES

HALOGEN FREE
 PACKAGE TA-EMBOSSED TAPE
 RIGHT ANGLE(LOWER CONTACT TYPE)
 FRONT FLIP TYPE
 1u"~3u" GOLD FLASH (NICKEL BARRIER)
 NO. OF CONTACTS

4.RATING:

OPERATING VOLTAGE:50V AC
 CURRENT RATING:0.2A
 OPERATING TEMPERATURE:-40°C ~ +85°C
 OPERATING HUMIDITY RANGE:RELATIVE HUMIDITY 85% MAX
 (NO CONDENSATION)
 STORAGE TEMPERATURE RANGE:-10°C ~ +50°C
 STORAGE HUMIDITY RANGE:RELATIVE HUMIDITY 85% MAX
 (NO CONDENSATION)

REV.	ECO NO.	DATE	SIGN	DESCRIPTION
E	ECO11028	20111025	Rory	MODIFY PROFILE.
F	ECO2012008	20120113	Rory	MODIFY MARK
G	ECO2015034	20151020	Candy	取消乾燥劑

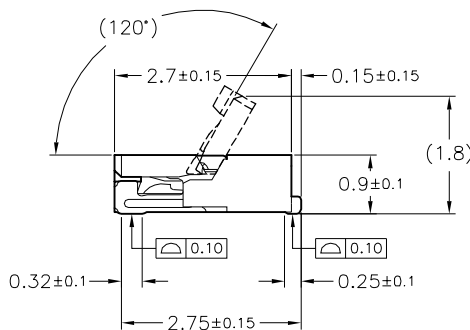
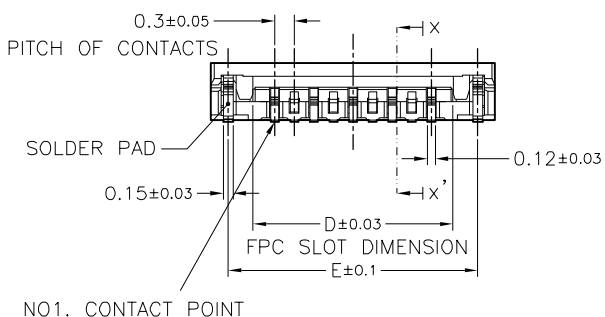
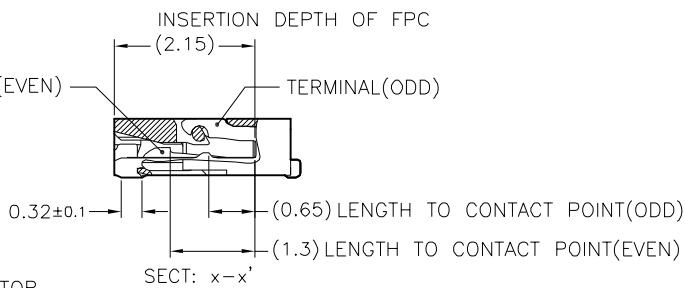
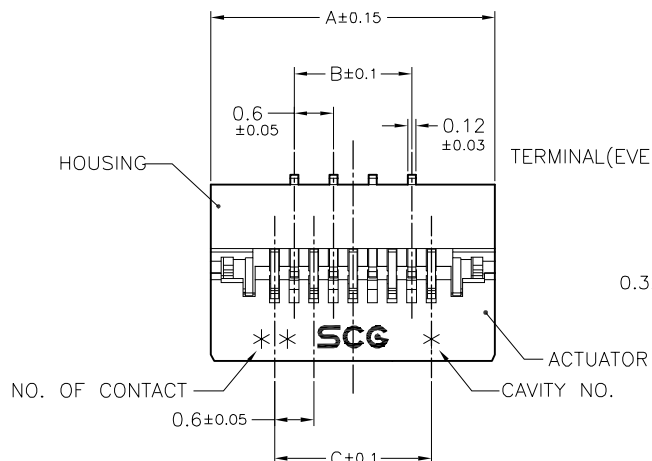

NO.OF CONTACTS	PART NUMBER	DIM. A	DIM. B	DIM. C	DIM. D	DIM. E
09	2FFBL309-09S22	4.35	1.8	2.4	3.06	3.82
11	2FFBL309-11S22	4.95	2.4	3.0	3.66	4.42
13	2FFBL309-13S22	5.55	3.0	3.6	4.26	5.02
15	2FFBL309-15S22	6.15	3.6	4.2	4.86	5.62
17	2FFBL309-17S22	6.75	4.2	4.8	5.46	6.22
19	2FFBL309-19S22	7.35	4.8	5.4	6.06	6.82
21	2FFBL309-21S22	7.95	5.4	6.0	6.66	7.42
23	2FFBL309-23S22	8.55	6.0	6.6	7.26	8.02
25	2FFBL309-25S22	9.15	6.6	7.2	7.86	8.62
27	2FFBL309-27S22	9.75	7.2	7.8	8.46	9.22
29	2FFBL309-29S22	10.35	7.8	8.4	9.06	9.82
31	2FFBL309-31S22	10.95	8.4	9.0	9.66	10.42
33	2FFBL309-33S22	11.55	9.0	9.6	10.26	11.02
35	2FFBL309-35S22	12.15	9.6	10.2	10.86	11.62
37	2FFBL309-37S22	12.75	10.2	10.8	11.46	12.22
39	2FFBL309-39S22	13.35	10.8	11.4	12.06	12.82
41	2FFBL309-41S22	13.95	11.4	12.0	12.66	13.42
43	2FFBL309-43S22	14.55	12.0	12.6	13.26	14.02
45	2FFBL309-45S22	15.15	12.6	13.2	13.86	14.62
49	2FFBL309-49S22	16.35	13.8	14.4	15.06	15.82
51	2FFBL309-51S22	16.95	14.4	15.0	15.66	16.42
57	2FFBL309-57S22	18.75	16.2	16.8	17.46	18.22
61	2FFBL309-61S22	19.95	17.4	18.0	18.66	19.42
67	2FFBL309-67S22	21.75	19.2	19.8	20.46	21.22
71	2FFBL309-71S22	22.95	20.4	21.0	21.66	22.42

Singatron Enterprise Co., Ltd.

TITLE	0.3 PITCH,H=0.9mm FPC CONN.		
DWN	PART NO.	2FFBL309-xxS22-TAHO	
CHKD	SCALE 1:1	UNIT: mm	
APVD	SIZE: A3	SHEET:1 OF 5	REV:G

CUSTOMER COPY

HF RoHS COMPLIANT PRODUCT

REV.	ECO NO.	DATE	SIGN	DESCRIPTION
E	ECO11028	20111025	Rory	MODIFY PROFILE.
F	ECO2012008	20120113	Rory	MODIFY MARK
G	ECO2015034	20151020	Candy	取消乾燥劑

RECOMMENDED METAL MASK THICKNESS: $t=0.1\text{mm}$

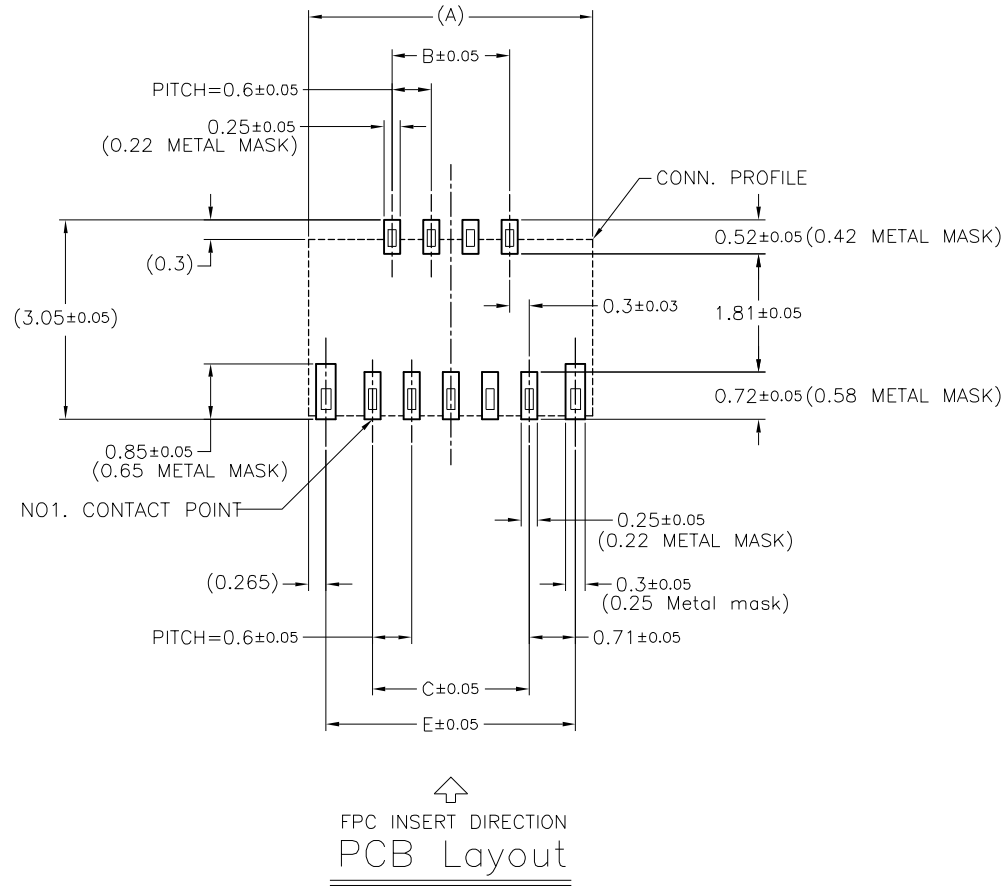

NO. OF CONTACTS	PART NUMBER	DIM. A	DIM. B	DIM. C	DIM. E
09	2FFBL309-09S22	4.35	1.8	2.4	3.82
11	2FFBL309-11S22	4.95	2.4	3.0	4.42
13	2FFBL309-13S22	5.55	3.0	3.6	5.02
15	2FFBL309-15S22	6.15	3.6	4.2	5.62
17	2FFBL309-17S22	6.75	4.2	4.8	6.22
19	2FFBL309-19S22	7.35	4.8	5.4	6.82
21	2FFBL309-21S22	7.95	5.4	6.0	7.42
23	2FFBL309-23S22	8.55	6.0	6.6	8.02
25	2FFBL309-25S22	9.15	6.6	7.2	8.62
27	2FFBL309-27S22	9.75	7.2	7.8	9.22
29	2FFBL309-29S22	10.35	7.8	8.4	9.82
31	2FFBL309-31S22	10.95	8.4	9.0	10.42
33	2FFBL309-33S22	11.55	9.0	9.6	11.02
35	2FFBL309-35S22	12.15	9.6	10.2	11.62
37	2FFBL309-37S22	12.75	10.2	10.8	12.22
39	2FFBL309-39S22	13.35	10.8	11.4	12.82
41	2FFBL309-41S22	13.95	11.4	12.0	13.42
43	2FFBL309-43S22	14.55	12.0	12.6	14.02
45	2FFBL309-45S22	15.15	12.6	13.2	14.62
49	2FFBL309-49S22	16.35	13.8	14.4	15.82
51	2FFBL309-51S22	16.95	14.4	15.0	16.42
57	2FFBL309-57S22	18.75	16.2	16.8	18.22
61	2FFBL309-61S22	19.95	17.4	18.0	19.42
67	2FFBL309-67S22	21.75	19.2	19.8	21.22
71	2FFBL309-71S22	22.95	20.4	21.0	22.42

Singatron Enterprise Co., Ltd.

TITLE	0.3 PITCH, H=0.9mm FPC CONN.		
DWN	PART NO.	2FFBL309-xxS22-TAHO	
CHKD	SCALE 1:1	UNIT: mm	
APVD	SIZE: A3	SHEET: 2 OF 5	REV: G

CUSTOMER COPY

HF

RoHS COMPLIANT PRODUCT
APPLICABLE FPC

(NORMAL FPC)

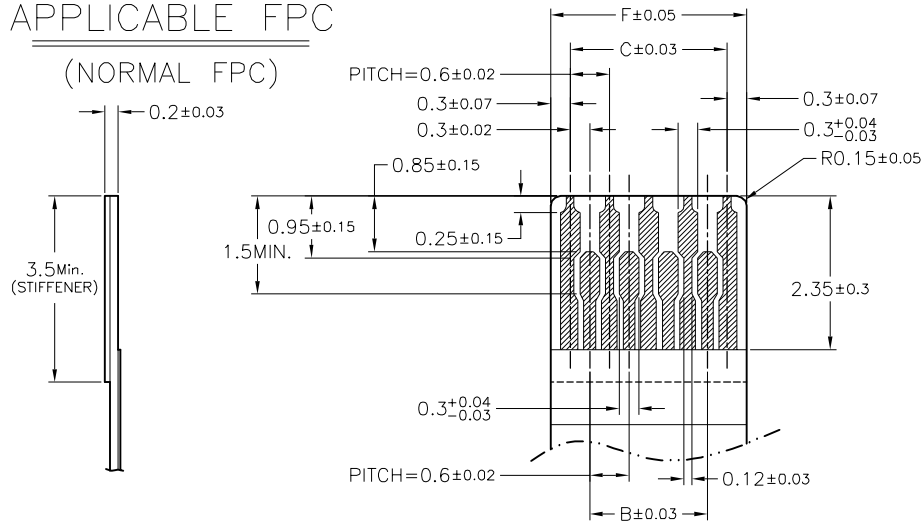

FPC CONSTRUCTION
(RECOMMENDED SPECIFICATION)

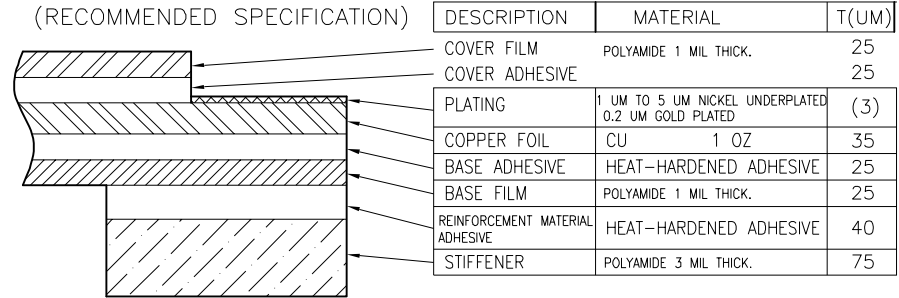

APPLICABLE FPC

(FPC WITH TABS)

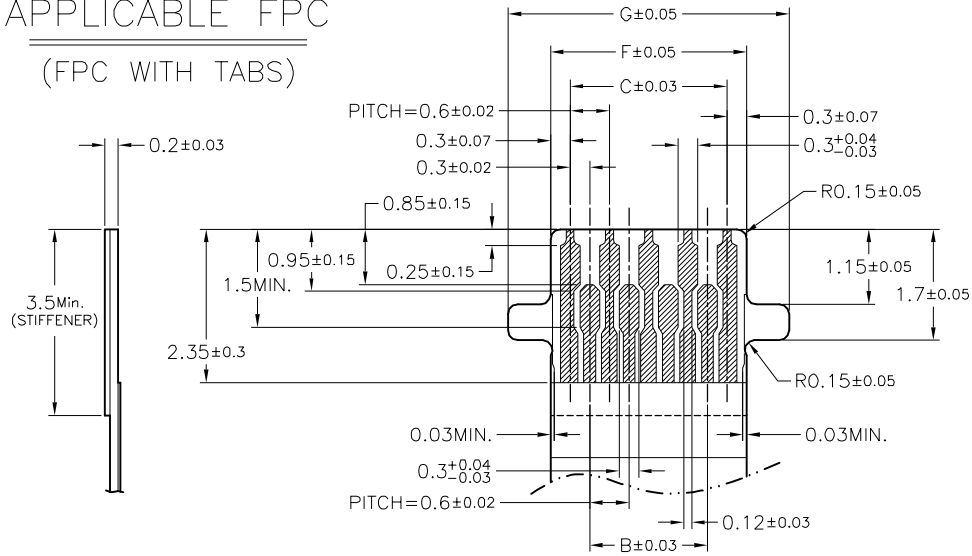

NO. OF CONTACTS	PART NUMBER	DIM. B	DIM. C	DIM. F	DIM. G
09	2FFBL309-09S22	1.8	2.4	3.0	4.3
11	2FFBL309-11S22	2.4	3.0	3.6	4.9
13	2FFBL309-13S22	3.0	3.6	4.2	5.5
15	2FFBL309-15S22	3.6	4.2	4.8	6.1
17	2FFBL309-17S22	4.2	4.8	5.4	6.7
19	2FFBL309-19S22	4.8	5.4	6.0	7.3
21	2FFBL309-21S22	5.4	6.0	6.6	7.9
23	2FFBL309-23S22	6.0	6.6	7.2	8.5
25	2FFBL309-25S22	6.6	7.2	7.8	9.1
27	2FFBL309-27S22	7.2	7.8	8.4	9.7
29	2FFBL309-29S22	7.8	8.4	9.0	10.3
31	2FFBL309-31S22	8.4	9.0	9.6	10.9
33	2FFBL309-33S22	9.0	9.6	10.2	11.5
35	2FFBL309-35S22	9.6	10.2	10.8	12.1
37	2FFBL309-37S22	10.2	10.8	11.4	12.7
39	2FFBL309-39S22	10.8	11.4	12.0	13.3
41	2FFBL309-41S22	11.4	12.0	12.6	13.9
43	2FFBL309-43S22	12.0	12.6	13.2	14.5
45	2FFBL309-45S22	12.6	13.2	13.8	15.1
49	2FFBL309-49S22	13.8	14.4	15.0	16.3
51	2FFBL309-51S22	14.4	15.0	15.6	16.9
57	2FFBL309-57S22	16.2	16.8	17.4	18.7
61	2FFBL309-61S22	17.4	18.0	18.6	19.9
67	2FFBL309-67S22	19.2	19.8	20.4	21.7
71	2FFBL309-71S22	20.4	21.0	21.6	22.9

Singatron Enterprise Co., Ltd.

TITLE	0.3 PITCH,H=0.9mm FPC CONN.		
DWN	PART NO.	2FFBL309-xxS22-TAHO	
CHKD	SCALE 1:1	UNIT: mm	⊕ ↻
APVD	SIZE: A3	SHEET: 3 OF 5	REV: G

CUSTOMER COPY

HF

EMBOSSED TAPE PACKING

REV.	ECO NO.	DATE	SIGN	DESCRIPTION
E	ECO11028	20111025	Rory	MODIFY PROFILE.
F	ECO2012008	20120113	Rory	MODIFY MARK
G	ECO2015034	20151020	Candy	取消乾燥劑

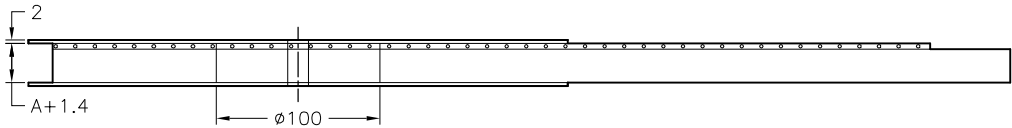

PULL OUT DIRECTION →

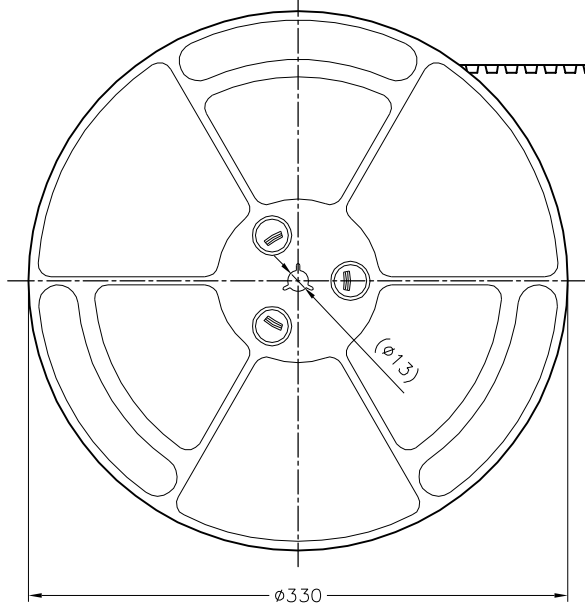

RoHS COMPLIANT PRODUCT

NOTE:

- 1.10 SPROCKET HOLE PITCH CUMULATIVE TOLERANCE ± 0.2
- 2.CARRIER CAMBER IS WITHIN 1 mm IN 250mm.
- 3.MATERIAL : BLACK CONDUCTIVE POLYSTYRENE ALLOY.
- 4.THICKNESS : 0.3 ± 0.05 mm.
- 5.COMPONENT LOAD PER 13" REEL : 5000PCS.
- 6.FOR TAPE WIDTH (DIMENSION A) 16 AND 24mm A PILOT HOLE IS PROVIDED ON ONE SIDE.
FOR TAPE WIDTH (DIMENSION A) 32 AND 44mm PILOT HOLES ARE PROVIDED ON BOTH SIDES.

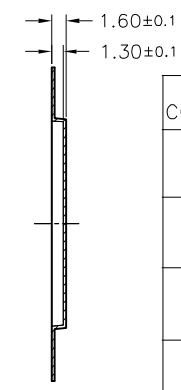
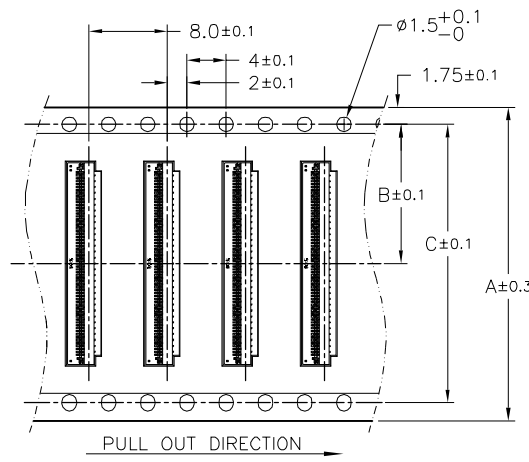
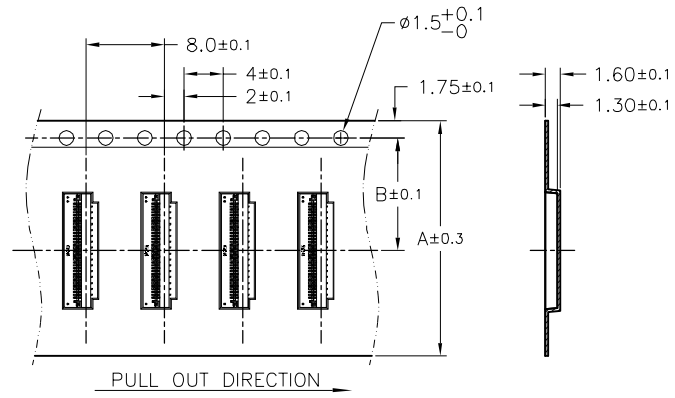

NO.OF CONTACTS	PART NUMBER	DIM. A	DIM. B	DIM. C
9	2FFBL309-09S22	16	7.5	—
25	2FFBL309-25S22			
27	2FFBL309-27S22	24	11.5	—
51	2FFBL309-51S22			
57	2FFBL309-57S22	32	14.2	28.4
67	2FFBL309-67S22			
71	2FFBL309-71S22	44	20.2	40.4

Singatron Enterprise Co., Ltd.

TITLE	0.3 PITCH,H=0.9mm FPC CONN.		
DWN	PART NO. 2FFBL309-xxS22-TAHO		
CHKD	SCALE 1:1	UNIT: mm	
APVD	SIZE: A3	SHEET: 4 OF 5	REV: G

CUSTOMER COPY

HF RoHS COMPLIANT PRODUCT

REV.	ECO NO.	DATE	SIGN	DESCRIPTION
E	ECO11028	20111025	Rory	MODIFY PROFILE.
F	ECO2012008	20120113	Rory	MODIFY MARK
G	ECO2015034	20151020	Candy	取消乾燥劑

紙板(上)
PASTEBOARD(UPPER)
(2)

塑膠袋
PLASTIC BAG
(4)

三角隔板
TRIANGLE PARTITION
(3)

紙板(下)
PASTEBOARD(LOWER)
(2)

外箱
CARTON
(1)

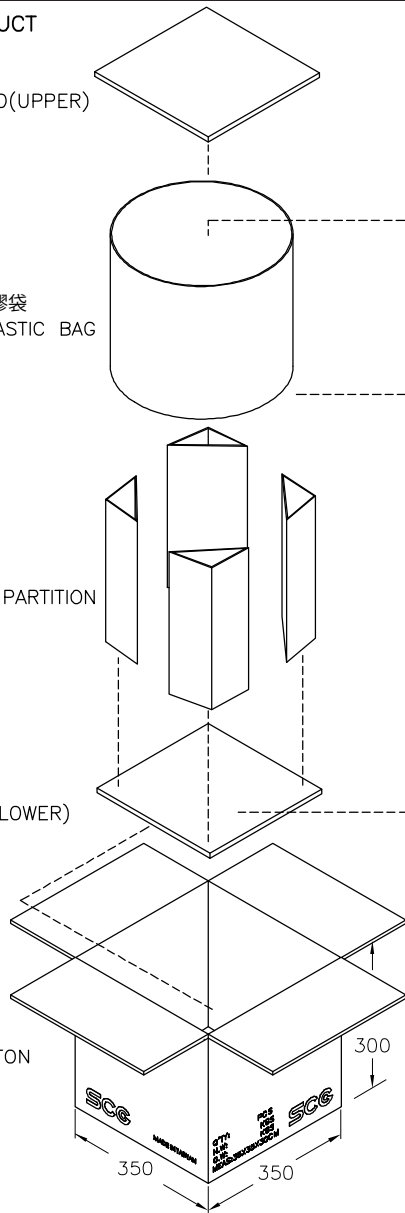

氣泡袋
BUBBLE BAG
(6)

TAPE & REEL
(5)

	NO. OF CONTACTS	(1)外箱	(2)紙板	(3)三角隔板	(4)塑膠袋	(5)塑膠圓盤	(6)氣泡袋
	9~25	1	2	4	1	9	9
	27~51	1	2	4	1	7	7
	57~67	1	2	4	1	6	6
	71	1	2	4	1	5	5

Singatron Enterprise Co., Ltd.

TITLE	0.3 PITCH,H=0.9mm FPC CONN.		
DWN	PART NO. 2FFBL309-xxS22-TAHO		
CHKD	SCALE 1:1	UNIT: mm	
APVD	SIZE: A3	SHEET: 5 OF 5	REV: G

CUSTOMER COPY