

1 2 3 4 5 6 7 8

F

E

D

C

B

A

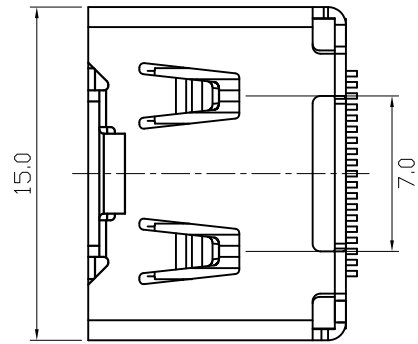
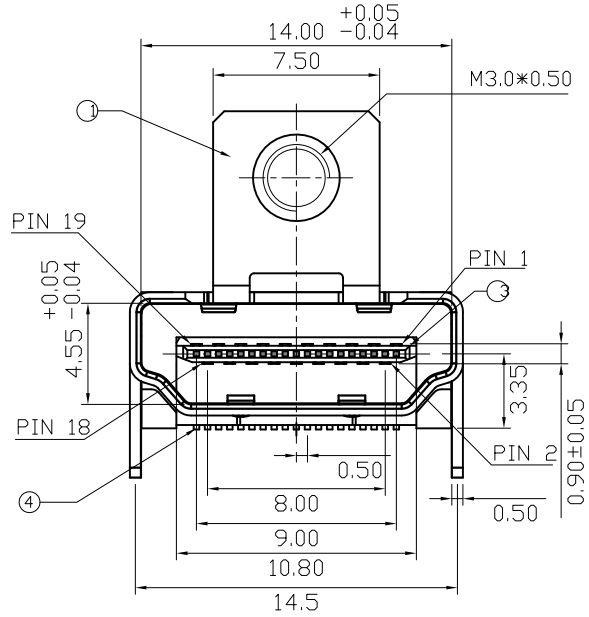

TOP VIEW

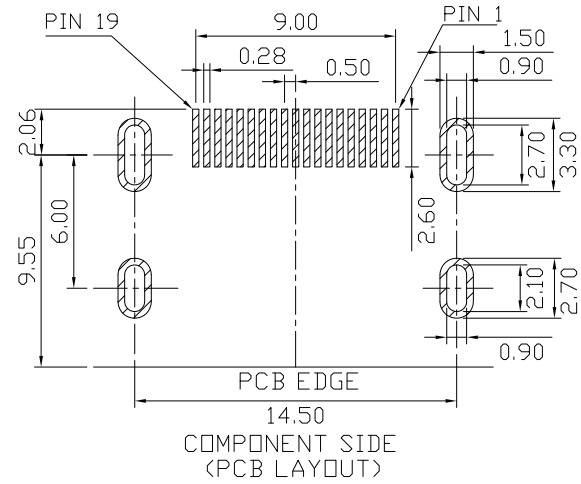
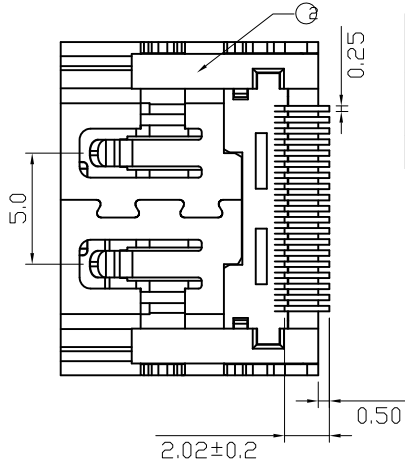
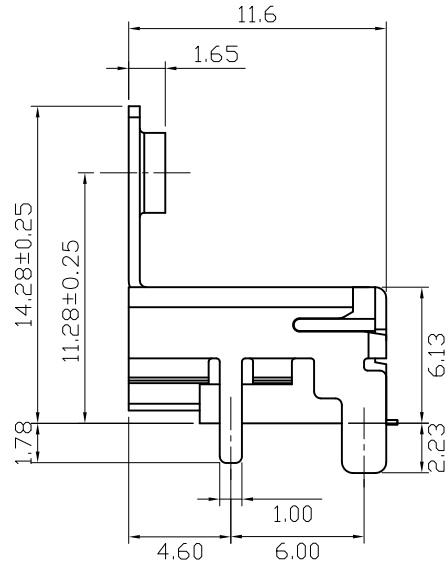

COMPONENT SIDE
(PCB LAYOUT)

NO.	NAME	MATERIAL	FINISH	Q'TY	REMARK
1	SHELL	BRASS T:0.50	NICKEL PLATED	1	Ni80~120u"
2	BODY	LCP+GF30%	GRAY	1	
3	CENTER PASTERN	LCP+GF30%	GRAY	1	
4	TERMINAL	PHOS. BRONZE T:0.20	GOLD/TIN PLATED	19	Gold15u", Ni40~60u" TIN120~200u"

Specification:

- ❖ Contact Resistance: Unmated Plug Socket, 30m Ohm. Maximum.
Mated Plug Socket, 60m Ohm. Maximum.
- ❖ Insulation Resistance: 100M Ohm Min. At 500 VDC.
- ❖ Rated Voltage And Current: AC 40V, 0.5A Minimum.
- ❖ Dielectric Withstanding Voltage: 500V AC (rms) For 1 Minute.
- ❖ Insertion Force: Type A- 44.1N Maximum.
- ❖ Extraction Force: Type A- 9.8N Minimum, 39.2N Maximum.
- ❖ Durability: Type A- 10000 Cycles At 100±50 Cycles Per Hour.
Life Test After: Type A- Insertion/Extraction Force: 6N Minimum.
- ❖ Operating Temperature: -20°C ~ +85°C.



Singatron Enterprise Co., Ltd.

TOLERANCE

- .X ±0.38
- .X ±0.25
- .XX ±0.13
- .XXX ±0.05

TITLE	HDMI A RECEPTACLE			
DWN	TINA	PART NO. 2HE-KRPS10A32N2AL		
CHKD	30-12-09	SCALE 1:1	UNIT: mm	④
APVD		SIZE: A3	SHEET: 1 OF 1	REV: A1
CUSTOMER COPY				

1 2 3 4 5 6 7 8