

DATE CODE:
YYMMDD
(YY-YEAR
MM-MONTH
DD-DAY)

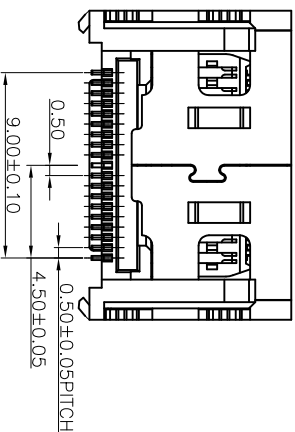

Recommend PCB Layout
Tolerance: ±0.05mm (Component Side)
Recommend PCB THICKNESS: 1.20mm

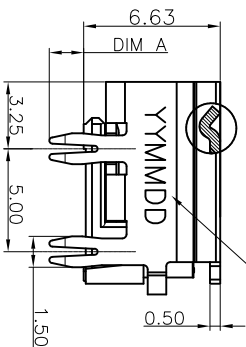
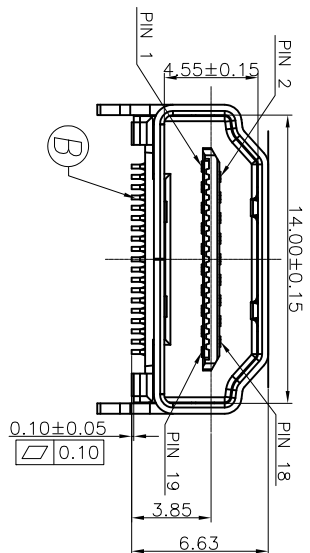
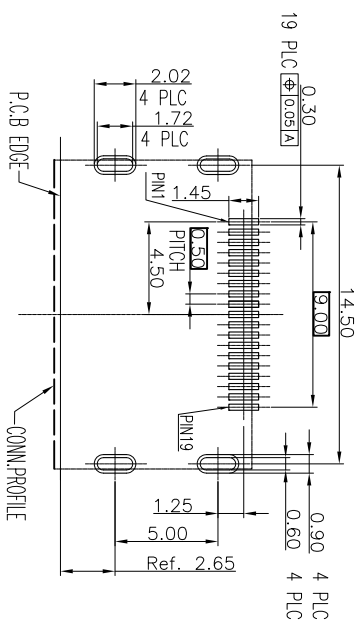

REV.	ECN NO OR DESCRIPTION	REVISED	DATE
A	ECN NO: L110078 2HE1528-001111 Delete: 2HE1528-001211	NY-C	2011.07.20
B	ECN NO: L110137	NY-C	2011.11.28

- SPECIFICATIONS:
- OTHER GENERAL SPEC. TO REFER "2HE1503 SERIES SPEC";
 - TO CONFORM TO SINGATRON HAZARDOUS SUBSTANCE FREE SPEC.
 - HALOGEN FREE PRODUCT IDENTIFICATION LABEL ON PACKAGING:
 - REFLOW SOLDER CAPABLE 260°C 10SECS.
 - FOR REFLOW SOLDERING LEAD-FREE PROCESS.
 - PACKAGE: SEE "2HE1528 SERIES " PACKAGE.

PART NO.
2HE1528-001111

PACKAGE:
1: TAPE & REEL
HOUSING COLOR
1: BLACK
CONTACT PLATING
1: GOLD FLASH

DIM A:
1: 1.8mm

E	INK		BLACK COLOR
D	INSULATION FILM	1	MYLAR
C	SHELL	1	COPPER ALLOY
B	CONTACT	19	COPPER ALLOY
A	HOUSING	1	LCP UL 94V-0
NO	DESCRIPTION	QTY	MATERIAL
UNLESS OTHERWISE SPECIFIED TOLERANCES			

Singaton Enterprise Co., Ltd.
信音企業股份有限公司

DECIMALS:	ANGLES:	TITLE	HDM TYPE	SCALE: N/A	UNIT:	SHEET:	REV:
X	±0.5	X	±2°		mm	1 OF 1	B
X.X	±0.3	X.X	±1°		mm		
X.XX	±0.2						