

REV.	ECN NO OR DESCRIPTION	REVISED	DATE
A	PDR RELEASE	Even	2017.04.12

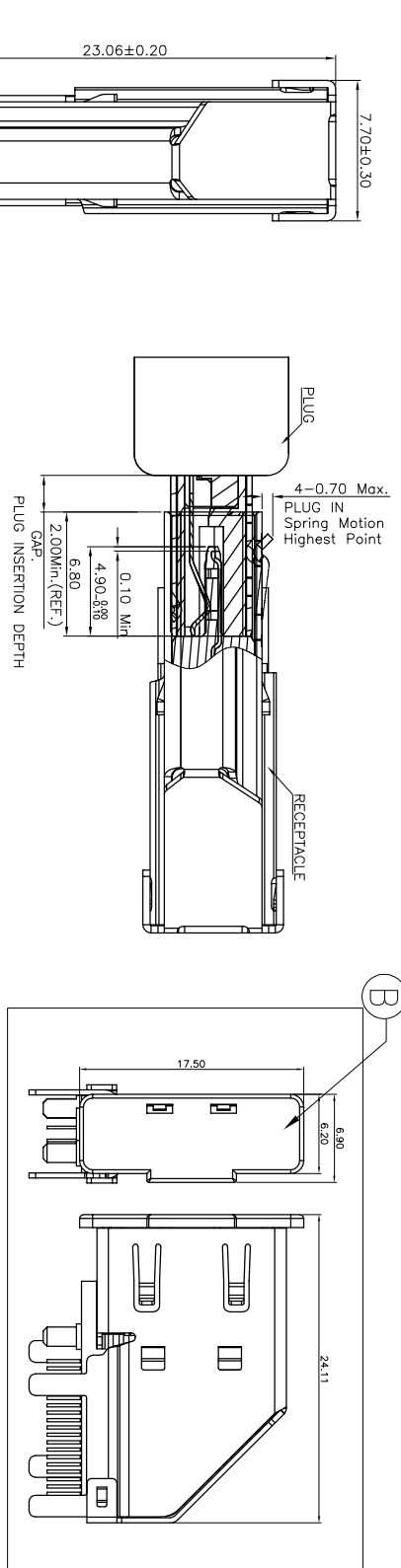

- SPECIFICATIONS:**
- ELECTRICAL CHARACTERISTICS:**
 - CURRENT RATING: 0.5 AMP.
 - VOLTAGE RATING: 40V.
 - CONTACT RESISTANCE: 30mΩ MAX.
 - INSULATION RESISTANCE: 100MΩ MIN. @ 500V DC.
 - DIELECTRIC WITHSTANDING VOLTAGE: 500V AC FOR 1 MINUTE.
 - MECHANICAL CHARACTERISTICS:**
 - INSERTION FORCE: 4.5kgf MAX.
 - WITHDRAWAL FORCE: 1.0~4.0kgf.
 - LIFE TEST: 10,000 CYCLES.
 - OPERATING TEMPERATURE: -25°C TO +85°C.
 - OTHER GENERAL SPEC. TO REFER "2HE1542-510111F SPEC".
 - TO CONFORM TO THE SINGATRON HAZARDOUS SUBSTANCE FREE SPEC.
 - HALOGEN FREE PRODUCT IDENTIFICATION LABEL ON PACKAGING.
 - PACKAGE: SEE "2HE1542-510111F" PACKAGE.
 - FOR REFLOW SOLDERING LEAD-FREE PROCESS.

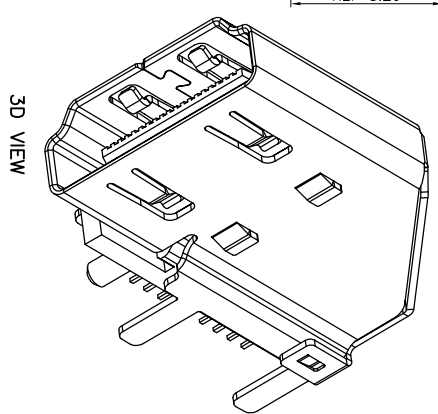
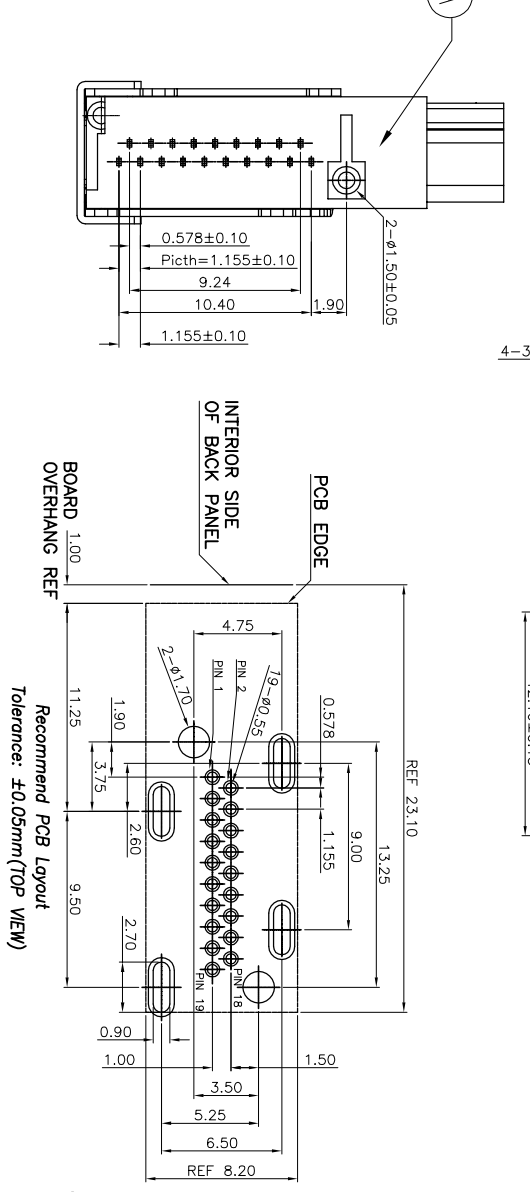
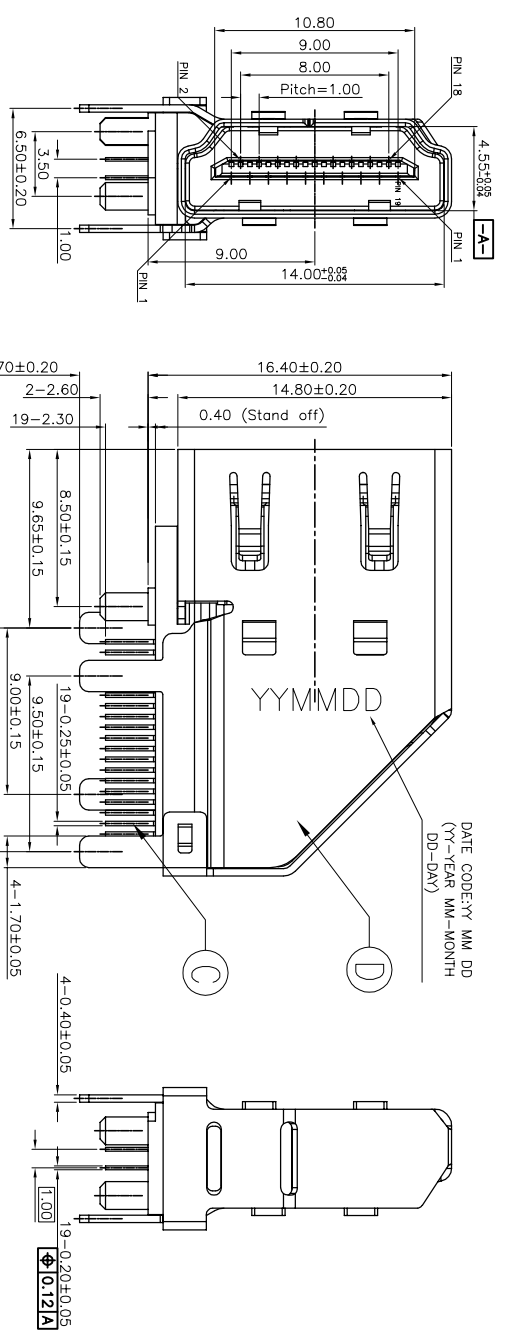

PART NO.
2HE1542-510111F

SUFFIX: HALOGEN FREE
PACKAGE
 1: TRAY
HOUSING COLOR
 1: BLACK
CONTACT PLATING
 1: GOLD FLASH ON CONTACT AREA,
 MATTE 100u" TIN ON SOLDER AREA
 50u" MIN NICKEL UNDERPLATED OVERALL

OPTIONAL
 1: W/O KINK FOOT

NO	DESCRIPTION	QTY	MATERIAL	PLATING & COLOR
D	SHELL	1	SUS304-1/2H	N: 50u" PLATING ALL OVER
C	CONTACT	19	C2680R-H	SEE PART NO.
B	CAP	1	LCP E130I UL94V-0	BLACK
A	HOUSING	1	LCP E130I UL94V-0	BLACK
NO	DESCRIPTION	QTY	MATERIAL	PLATING & COLOR

UNLESS OTHERWISE SPECIFIED TOLERANCES

DECIMALS: ANGLES:

X : ±0.5 X : ±2°
 X.X : ±0.3 X.X : ±1°
 X.XX : ±0.2

TITLE HDMI TYPE A FEMALE VERTICAL & DIP TYPE
DATE ENH 2017.04.12
PART NO. 2HE1542-510111F
SCALE 1:1
UNIT: mm
SIZE: A3
SHEET: 1 OF 1
REV: A

Singatron Enterprise Co., Ltd.
信亨企業股份有限公司

CUSTOMER COPY