

REV.	ECN NO OR DESCRIPTION	REVISED	DATE
A	PDR RELEASE 2HE1576-000111F → 2HE1576-X00111F	IVY-C	2011.03.22
B	ECN NO:L130014	IVY-C	2013.08.26
C	ECN NO:L150040	IVY-C	2015.07.16

SPECIFICATIONS:

- ELECTRICAL CHARACTERISTICS:
  - CURRENT RATING: 0.5 AMP.
  - VOLTAGE RATING: 40V.
  - CONTACT RESISTANCE: 30mΩ MAX.
  - INSULATION RESISTANCE: 100MΩ MIN. @ 500V DC.
  - DIELECTRIC WITHSTANDING VOLTAGE: 500V AC FOR 1 MINUTE.
- MECHANICAL CHARACTERISTICS:
  - INSERTION FORCE: 4.5Kgf MAX.
  - WITHDRAWAL FORCE: 0.7~2.5Kgf.
- LIFE TEST: 5,000 CYCLES.
- OTHER GENERAL SPEC. TO REFER "HDMI SERIES SPEC".
- TO CONFORM TO THE SINGATRON HAZARDOUS SUBSTANCE FREE SPEC.
- HALOGEN FREE PRODUCT IDENTIFICATION LABEL ON PACKAGING: 
- PACKAGE: SEE "2HE1576 SERIES" PACKAGE.
- FOR REFLOW SOLDERING LEAD-FREE PROCESS.

PART NO.

2HE1576-X00111F

SUFFIX: HALOGEN FREE

PACKAGE

1: TAPE AND REEL

HOUSING COLOR

1: BLACK

CONTACT PLATING

1: GOLD FLASH ON CONTACT AREA,  
MATTE TIN ON SOLDER AREA

LENGTH OF SHELL LEG

0: DIM A=1.50

1: DIM A=1.00

E	INK		BLACK
D	MYLAR	1	
C	SHELL	1 C2680	NICKEL
B	CONTACT	19 C5191	SEE PART NO.
A	HOUSING	1 LCP UL 94V-0	BLACK
NO	DESCRIPTION	QTY	MATERIAL PLATING & COLOR

UNLESS OTHERWISE SPECIFIED TOLERANCES

 Singatron Enterprise Co., Ltd.  
信音企業股份有限公司

DECIMALS:	ANGLES:	TITLE	HDMI C TYPE FEMALE, SMT, W/O FLANGE	
X : ±0.5	X : ±2°	DWN	IVY-C 2015.07.16	PART NO. 2HE1576-X00111F
XX : ±0.3	XX : ±1°	CHKD	ANGELA 2015.07.16	SCALE 1:1 UNIT: mm
XX.XX : ±0.2		APVD	ANGELA 2015.07.16	SIZE: A3 SHEET: 1 OF 1 REV: C

CUSTOMER COPY

文件編號: RD-00111F-A

2015/07/17 13:17:16  
2015/07/20 08:48:33

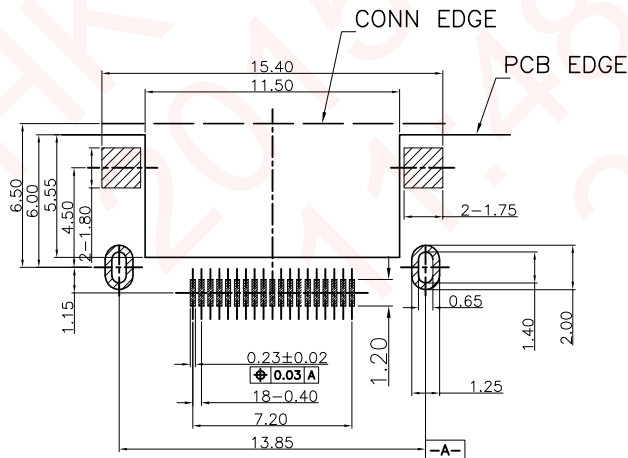
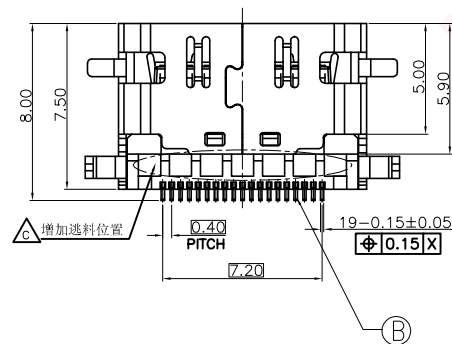
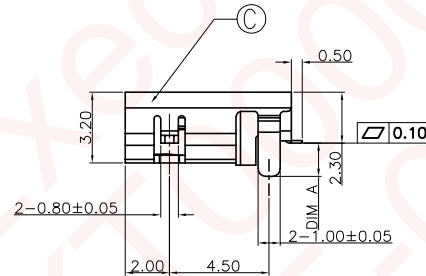
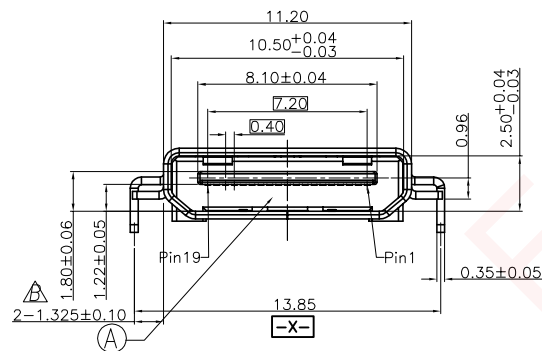
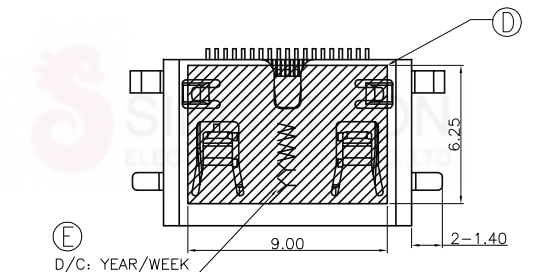

RECOMMENDED PCB LAYOUT(TOP VIEW)  
(THICKNESS=0.8±0.05mm)  
TOLERANCE = ±0.05

商標專員  
產品技術部  
(HKT)  
范義秀琴