

REV.	ECN NO OR DESCRIPTION	REVISED	DATE
A	PDR RELEASE	IVY-C	2011.05.30
B	ECN NO: L150093	IVY-C	2015.07.22

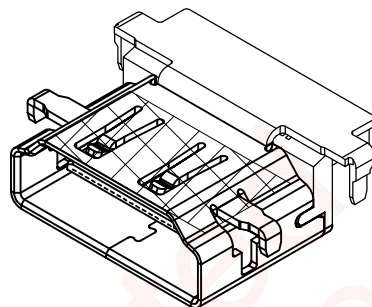
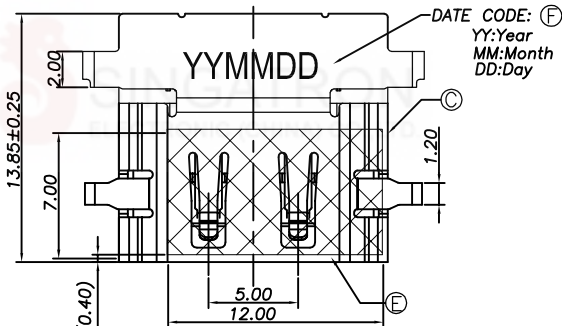

3D VIEW

SPECIFICATIONS:

- ELECTRICAL CHARACTERISTICS:
  - CURRENT RATING: 0.5 AMP.
  - VOLTAGE RATING: 40V.
  - CONTACT RESISTANCE: 30mΩ MAX.
  - INSULATION RESISTANCE: 100MΩ MIN. @ 500V DC.
  - DIELECTRIC WITHSTANDING VOLTAGE: 500V AC FOR 1 MINUTE.
- MECHANICAL CHARACTERISTICS:
  - INSERTION FORCE: 4.5Kgf MAX.
  - WITHDRAWAL FORCE: 1.0~4.0Kgf.
- LIFE TEST: 10,000 CYCLES.
- OTHER GENERAL SPEC. TO REFER "HDMI SERIES SPEC".
- TO CONFORM TO THE SINGATRON HAZARDOUS SUBSTANCE FREE SPEC.
- HALOGEN FREE PRODUCT IDENTIFICATION LABEL ON PACKAGING:
- PACKAGE: SEE "2HE1584 SERIES" PACKAGE.
- FOR REFLOW SOLDERING LEAD-FREE PROCESS.

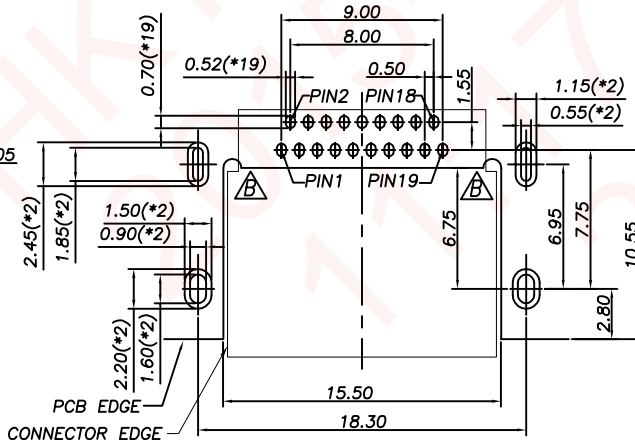
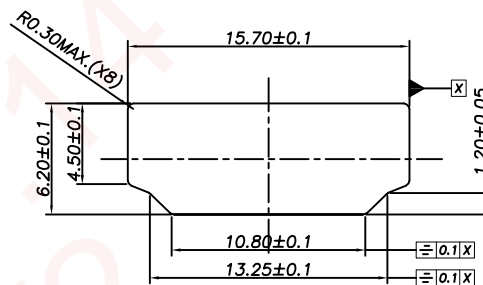
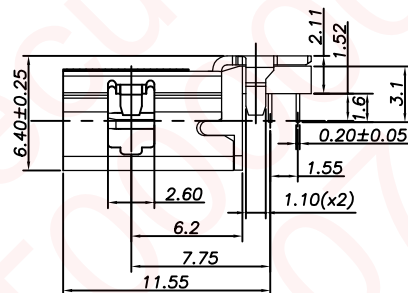
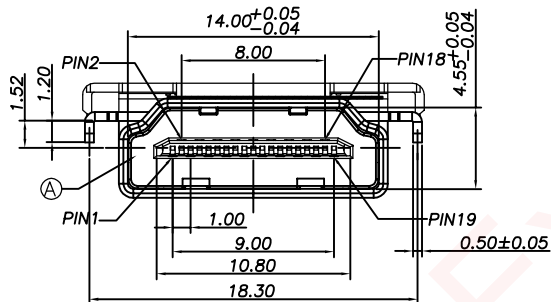

RECOMMENDED P.C.B. LAYOUT (T:1.20±0.05mm)  
 TOLERANCE UNSPECIFIED ±0.05mm

2HE1584-000111F

- SUFFIX: HALOGEN FREE
- PACKAGE: 1: TAPE AND REEL
- HOUSING COLOR: 1: BLACK
- CONTACT PLATING: 1: GOLD FLASH ON CONTACT AREA, TIN ON SOLDER AREA

F	INK	1		BLACK
E	MYLAR	1	KAPTON FILM	YELLOW
D	COVER	1	HIGH TEMP. THERMOPLASTIC	BLACK
C	SHELL	1	COPPER ALLOY	NICKEL
B	CONTACT	19	COPPER ALLOY	SEE PART NO.
A	HOUSING	1	HIGH TEMP. THERMOPLASTIC UL 94V-0	BLACK

NO	DESCRIPTION	QTY	MATERIAL	PLATING & COLOR
UNLESS OTHERWISE SPECIFIED TOLERANCES			Singatron Enterprise Co., Ltd. 信音企業股份有限公司	
DECIMALS:		ANGLES:		TITLE
X	±0.5	X	±2°	HDMI A TYPE FEMALE, DIP, REVERSE, SINKING 1.52
X.X	±0.3	X.X	±1°	DWN
X.XX	±0.2			IVY-C 2015.07.22 PART NO. 2HE1584-000111F
CHKD		SCALE 1:1		UNIT: mm
APVD		SIZE: A3		SHEET: 1 OF 1
				REV: B
<b>CUSTOMER COPY</b>				