

REV.	ECN NO OR DESCRIPTION	REVISED	DATE
A	PDR RELEASE	IVY-C	2014.10.21

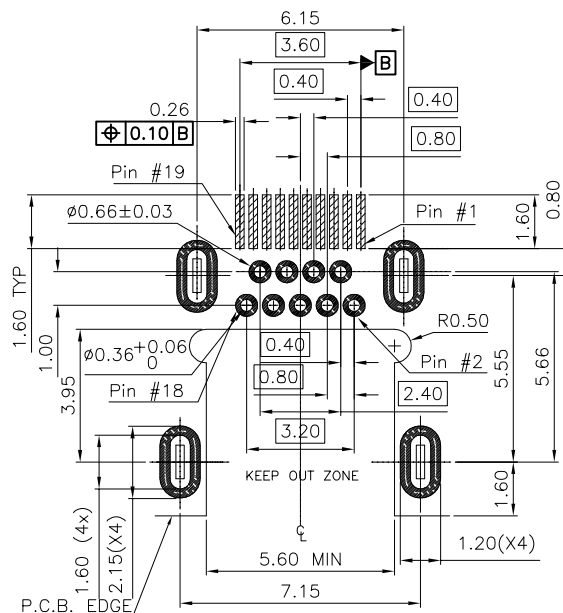

RECOMMENDED P.C.B. LAYOUT (T:1.0mm)
TOLERANCE UNSPECIFIED ±0.05mm

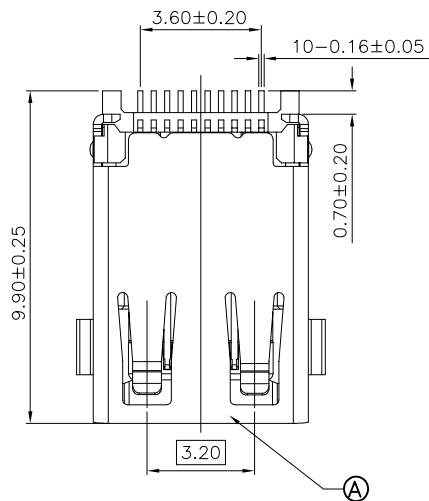
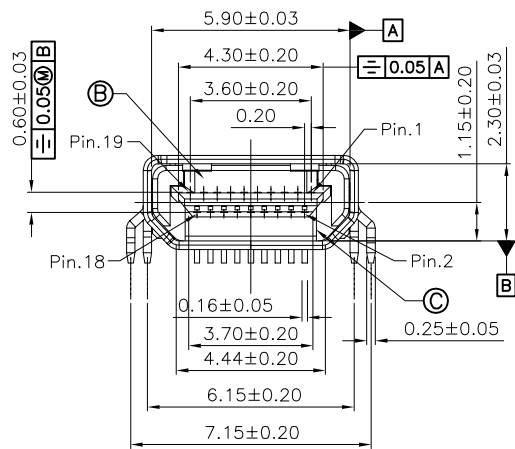
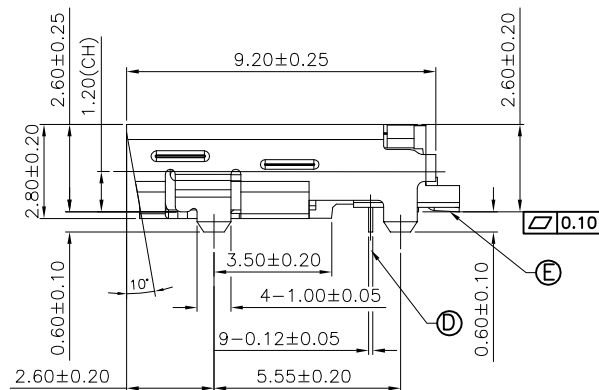

PART NO.
2HE1640-001112F

SHELL FRONT
1: WITH CHAMFER & LEG LENGTH 0.6mm

CONTACT PLATING
1: GOLD FLASH ON CONTACT AREA,
120u" TIN PLATING ON SOLDER AREA.
50u" NI UNDERPLATED OVERALL.

SUFFIX: HALOGEN FREE

PACKAGE
2: TAPE AND REEL (for QUANTA)

HOUSING COLOR
1: BLACK

SPECIFICATIONS:

- ELECTRICAL CHARACTERISTICS:
 - CURRENT RATING: 0.3 AMP.
 - VOLTAGE RATING: 40V.
 - INITIAL CONTACT RESISTANCE EXCLUDING CONDUCTOR RESISTANCE: 10mΩ MAX (TARGET DESIGN VALUE). AFTER TEST: Δ30mΩ MAX.
 - INSULATION RESISTANCE: 100MΩ MIN. @ 500V DC.
 - DIELECTRIC WITHSTANDING VOLTAGE: 250V AC FOR 1 MINUTE.
- MECHANICAL CHARACTERISTICS:
 - INSERTION FORCE: 4.5Kgf MAX.
 - WITHDRAWAL FORCE: 0.5~2.5Kgf.
- LIFE TEST: 5,000 CYCLES
- OTHER GENERAL SPEC. TO REFER "HDMI SERIES SPEC".
- TO CONFORM TO THE SINGATRON HAZARDOUS SUBSTANCE FREE SPEC.
- HALOGEN FREE PRODUCT IDENTIFICATION LABEL ON PACKAGING:
- PACKAGE: SEE "2HE1640-001112F" PACKAGE.
- FOR REFLOW SOLDERING LEAD-FREE PROCESS.

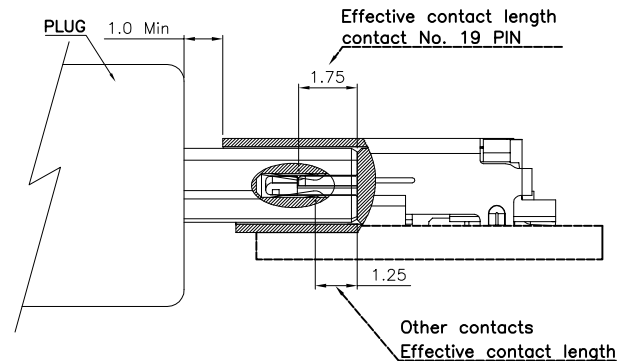

E	SMT CONTACT	10	C5191R-H, 0.12t	SEE PART NO.					
D	DIP CONTACT	9	C5191R-H, 0.12t	SEE PART NO.					
C	BOTTOM HOUSING	1	LCP+30%G.F UL94V-0	BLACK					
B	TOP HOUSING	1	LCP+30%G.F UL94V-0	BLACK					
A	SHELL	1	SUS201-1/2H, 0.25t	NICKEL					
NO	DESCRIPTION	QTY	MATERIAL	PLATING & COLOR					
UNLESS OTHERWISE SPECIFIED TOLERANCES			Singatron Enterprise Co., Ltd. 						
DECIMALS:		ANGLES:		TITLE					
X	:±0.5	X	:±2°	HDMI TYPE D FEMALE, DIP+SMT TYPE, CH=1.20					
X.X	:±0.3	X.X	:±1°	DWN W-C 2014.10.21					
X.XX	:±0.2			<table border="1"> <tr> <td>APVD</td> <td>ANGELA 2014.10.21</td> <td>SIZE: A3</td> <td>SHEET: 1 OF 1</td> <td>REV: A</td> </tr> </table>	APVD	ANGELA 2014.10.21	SIZE: A3	SHEET: 1 OF 1	REV: A
APVD	ANGELA 2014.10.21	SIZE: A3	SHEET: 1 OF 1	REV: A					

CUSTOMER COPY