

REV.	ECN NO. OR DESCRIPTION	REVISED	DATE
A	PDR RELEASE	NY-C	2014.01.20
B	ECN NO: L140041	NY-C	2014.04.15
C	ECN NO: L140050	NY-C	2014.05.13

SPECIFICATIONS:

- ELECTRICAL CHARACTERISTICS:**
 - CURRENT RATING: 0.3 AMP.
 - VOLTAGE RATING: 40V.
 - CONTACT RESISTANCE: 30mΩ MAX.
 - INSULATION RESISTANCE: 100MΩ MIN. @ 500V DC.
 - DIELECTRIC WITHSTANDING VOLTAGE: 250V AC FOR 1 MINUTE.
- MECHANICAL CHARACTERISTICS:**
 - INSERTION FORCE: 4.5kgf MAX.
 - WITHDRAWAL FORCE: 0.5~2.5kgf.
 - LIFE TEST: 5,000 CYCLES
 - OTHER GENERAL SPEC. TO REFER "HDMI SERIES SPEC".
 - TO CONFORM TO THE SINGATRON HAZARDOUS SUBSTANCE FREE SPEC.
 - HALOGEN FREE PRODUCT IDENTIFICATION LABEL ON PACKAGING.
 - PACKAGE: SEE "2HE1643-211111F" PACKAGE.
 - FOR REFLOW SOLDERING LEAD-FREE PROCESS.



PART NO.

2HE1643-211111F

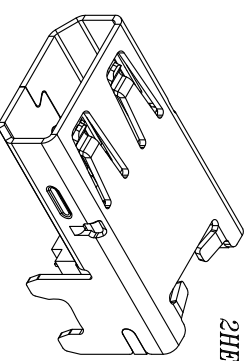

- SUFFIX: HALOGEN FREE
- PACKAGE
- 1: TAPE AND REEL
- HOUSING COLOR
- 1: BLACK
- CONTACT PLATING
- 1: GOLD FLASH OVERALL

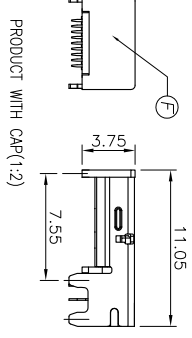
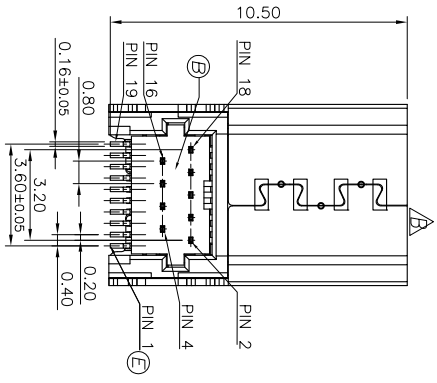
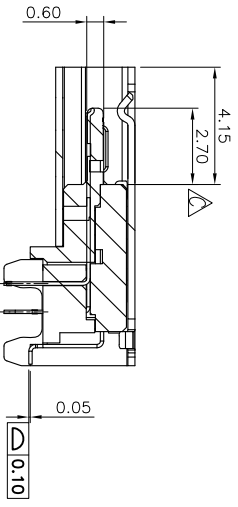
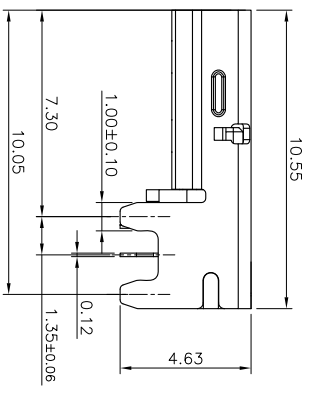
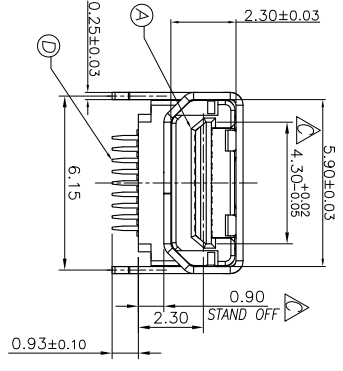
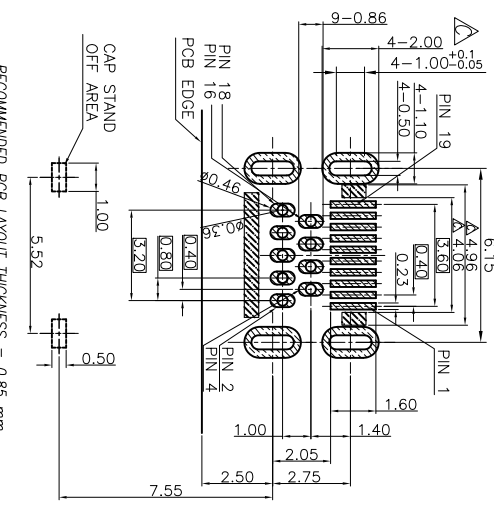
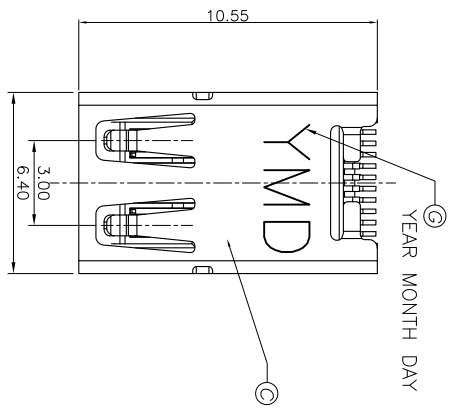

G	INK		BLACK
F	CAP	1	LCP E130I UL 94V-0
E	CONTACT-SMT	10	C5191R-H T=0.12
D	CONTACT-DIP	9	C5191R-H T=0.12
C	SHELL	1	SUS304-3/4H T=0.25
B	COVER	1	LCP E130I UL 94V-0
A	HOUSING	1	LCP E130I UL 94V-0
NO	DESCRIPTION	QTY	MATERIAL
UNLESS OTHERWISE SPECIFIED TOLERANCES			
Singatron Enterprise Co., Ltd. 信音企業股份有限公司			
TITLE: HDMI TYPE D FEMALE, SMT, SPECIAL CUTTING			
DWN	W-C:2014.05.13	PART NO.	2HE1643-211111F
CHKD		SCALE	1:1
APVD	AMEL2014.05.13	UNIT:	mm
		SIZE:	A3
		SHEET:	1 OF 1
		REV:	C
CUSTOMER COPY			