

DATE CODE: YYMMDD
 YY: YEAR
 MM: MONTH
 DD: DAY

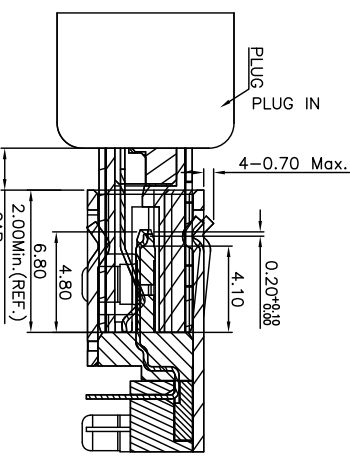
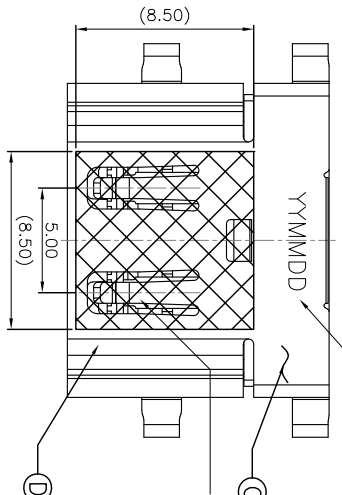

- SPECIFICATIONS:**
- ELECTRICAL CHARACTERISTICS:**
 - 1-1. CURRENT RATING: 0.5 AMP.
 - 1-2. VOLTAGE RATING: 40V.
 - 1-3. INITIAL CONTACT RESISTANCE EXCLUDING CONDUCTOR RESISTANCE: 10mΩ MAX. (TARGET DESIGN VALUE). AFTER TEST: Δ 30mΩ MAX.
 - 1-4. INSULATION RESISTANCE: 100MΩ MIN. @ 500V DC.
 - 1-5. DIELECTRIC WITHSTANDING VOLTAGE: 500V AC FOR 1 MINUTE.
 - MECHANICAL CHARACTERISTICS:**
 - 2-1. INSERTION FORCE: 4.5kgf MAX.
 - 2-2. WITHDRAWAL FORCE: 1.0~4.0kgf.
 - LIFE TEST:** 10,000 CYCLES.
 - OTHER GENERAL SPEC. TO REFER "2HE1679-000211F SPEC."**
 - TO CONFORM TO THE SINGATRON HAZARDOUS SUBSTANCE FREE SPEC.**
 - HALOGEN FREE PRODUCT IDENTIFICATION LABEL ON PACKAGING:**
 - PACKAGE: SEE "2HE1679-000211F" PACKAGE.**
 - FOR REFLOW SOLDERING LEAD-FREE PROCESS.**

PART NO.

2HE1679-000211F

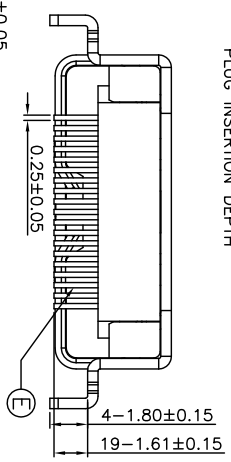
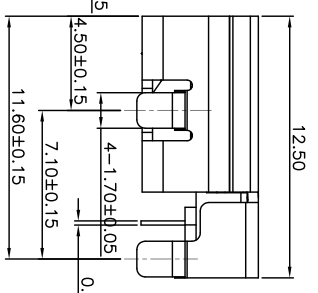
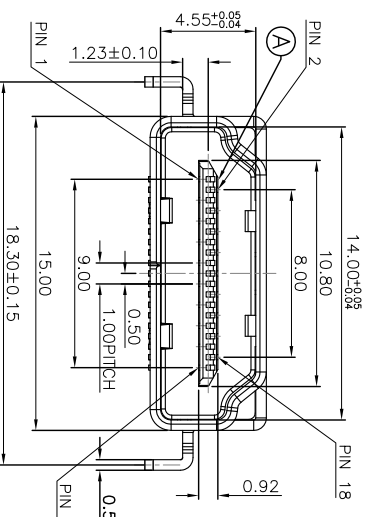

SUFFIX: HALOGEN FREE
 PACKAGE
 1: TAPE AND REEL
 HOUSING COLOR
 1: BLACK
 CONTACT PLATING
 2: Au 30u "ON CONTACT AREA,
 GOLD FLASH ON SOLDER AREA,
 NICKEL UNDERPLATED OVERALL.

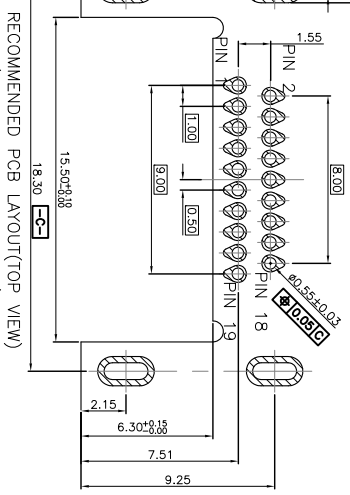
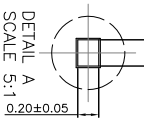
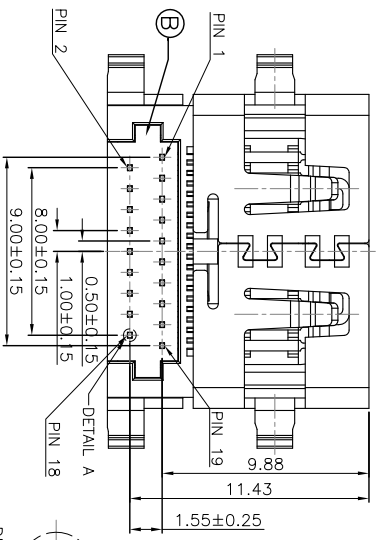

F	MYLAR	1	YELLOW
E	CONTACT	19	C2680-H SEE PART NO.
D	SHELL	1	SUS304 NICKEL
C	TOP COVER	1	LCP UL 94V-0 BLACK
B	BOTTOM COVER	1	LCP UL 94V-0 BLACK
A	HOUSING	1	LCP UL 94V-0 BLACK
NO	DESCRIPTION	QTY	MATERIAL PLATING & COLOR

UNLESS OTHERWISE SPECIFIED TOLERANCES

DECIMALS: ANGLES:

X : ±0.5 X : ±2°
 X.X : ±0.3 X.X : ±1°
 X.XX : ±0.2

TITLE: HDMI A TYPE FEMALE, SINKING, REVERSE, DIP TYPE, CH=1.23mm

DWN: BEN 2017/6/27 PART NO. 2HE1679-000211F

CHKD: MMEA 2017/6/27 SCALE 4:1 UNIT: mm

APVD: MMEA 2017/6/27 SIZE: A3 SHEET: 1 OF 1 REV: B

Singatron Enterprise Co., Ltd.
 信音企業股份有限公司

CUSTOMER COPY

REV.	ECN NO. OR DESCRIPTION	REVISED	DATE
A	PDR RELEASE	NY-C	2016.08.11
B	ECN NO: L170052	EVEN	2017.06.07