

REV/ECN NO OR DESCRIPTION	REVISED	DATE
A PDR RELEASE	NY-C	2014.09.03
B ECN NO: S180621-P	Chensong	2018.07.26

DATE CODE(X: YEAR  
M: Month D: Day)

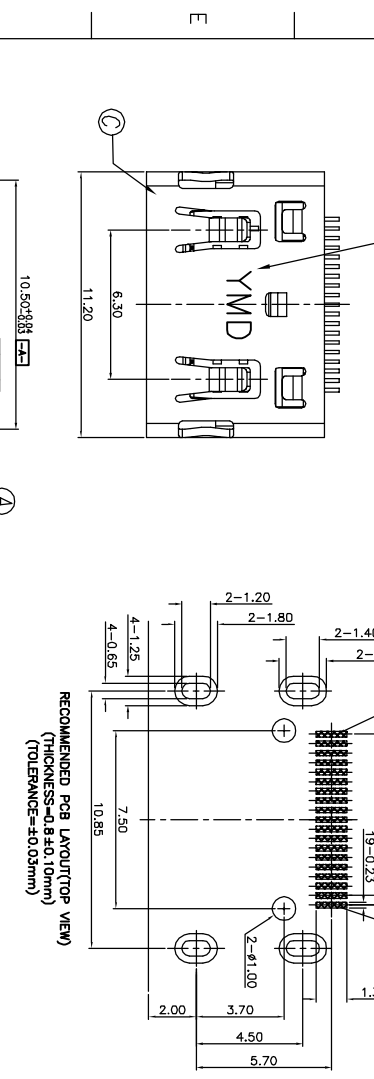

- SPECIFICATIONS:
- ELECTRICAL CHARACTERISTICS:
    - CURRENT RATING: 0.5 AMP.
    - VOLTAGE RATING: 40V.
    - INITIAL CONTACT RESISTANCE EXCLUDING CONDUCTOR RESISTANCE: 10mΩ MAX (TARGET DESIGN VALUE). AFTER TEST: Δ30mΩ MAX.
    - INSULATION RESISTANCE: 100MΩ MIN. @ 500V DC.
    - DIELECTRIC WITHSTANDING VOLTAGE: 500V AC FOR 1 MINUTE.
  - MECHANICAL CHARACTERISTICS:
    - INSERTION FORCE: 4.5Kgf MAX.
    - WITHDRAWAL FORCE: 0.7~2.5Kgf.
    - LIFE TEST: 5,000 CYCLES.
    - OTHER GENERAL SPEC. TO REFER "HDMI SERIES SPEC".
    - TO CONFORM TO THE SINGATRON HAZARDOUS SUBSTANCE FREE SPEC.
    - HALOGEN FREE PRODUCT IDENTIFICATION LABEL ON PACKAGING.
    - PACKAGE: SEE "2HE1680 SERIES" PACKAGE.
    - FOR REFLOW SOLDERING LEAD-FREE PROCESS.



HDMI TYPE A PIN ASSIGNMENT

PIN	Signal Assignment
1	TMDS Data2 Shield
2	TMDS Data2+
3	TMDS Data2-
4	TMDS Data1 Shield
5	TMDS Data1+
6	TMDS Data1-
7	TMDS Data0 Shield
8	TMDS Data0+
9	TMDS Data0-
10	TMDS Clock Shield
11	TMDS Clock+
12	TMDS Clock-
13	DDC/CEC Ground
14	CEC
15	SCL
16	SDA
17	Utility
18	+5V Power
19	Hot Plug Detect

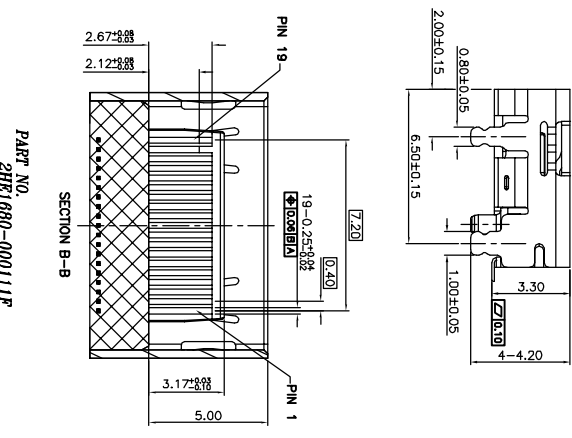
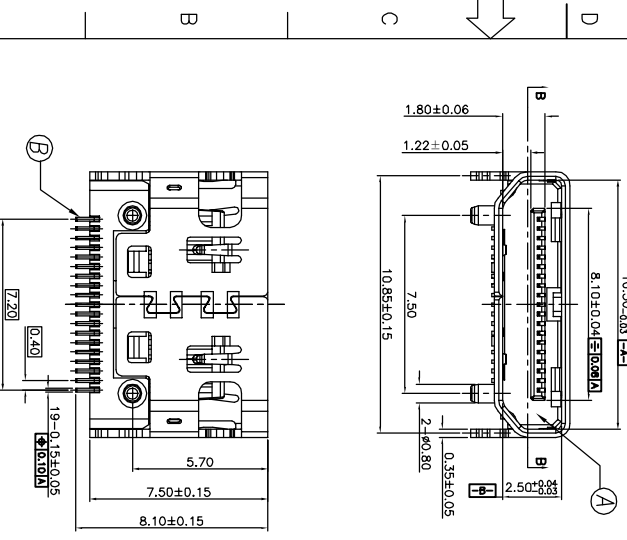
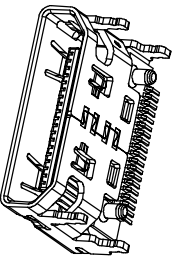
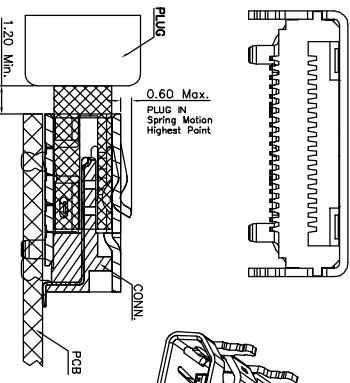

CONTACT PLATING: \_\_\_\_\_  
 1: GOLD FLASH ON MATING AREA  
 MATTE Sn 60~150u" ON SOLDERING AREA  
 60~150u" NICKEL UNDER PLATING OVERALL

SUFFIX: HALOGEN FREE  
 PACKAGE: TAPE AND REEL  
 HOUSING COLOR: 1: BLACK

D	INK					
C	SHELL	1	C2680-H, 0.35t			
B	CONTACT	19	C5191-H, 0.15t			
A	HOUSING	1	LCP ET30L, UL 94V-0			
NO	DESCRIPTION	QTY	MATERIAL	PLATING & COLOR		
UNLESS OTHERWISE SPECIFIED TOLERANCES						
Singatron Enterprise Co., Ltd.						
信亨企業股份有限公司						
TITLE: MINI HDMI C TYPE FEMALE, H=3.50mm						
DWG	Chensong	PART NO.	2HE1680-000111F			
CHKD		SCALE:	1:1	UNIT:	mm	
APVD		SIZE:	A3	SHEET:	1 OF 1	REV. B
CUSTOMER COPY						

For 神基