

REV.	ECN NO OR DESCRIPTION	REVISED	DATE
A	PDR RELEASE	IVY-C	2015.04.29

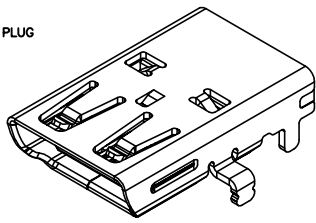
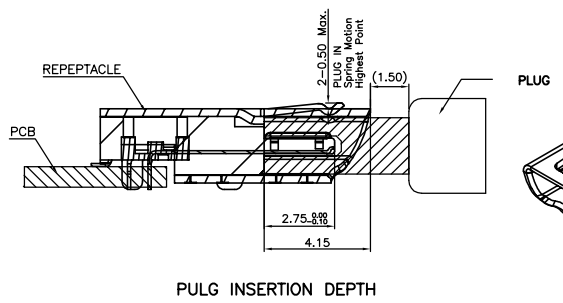
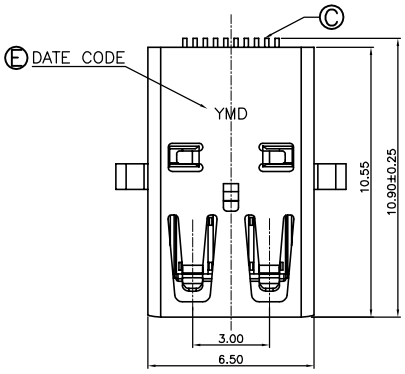

3D VIEW

SPECIFICATIONS:

- ELECTRICAL CHARACTERISTICS:
 - CURRENT RATING: 0.3 AMP.
 - VOLTAGE RATING: 40V.
 - CONTACT RESISTANCE: 30mΩ MAX.
 - INSULATION RESISTANCE: 100MΩ MIN. @ 500V DC.
 - DIELECTRIC WITHSTANDING VOLTAGE: 250V AC FOR 1 MINUTE.
- MECHANICAL CHARACTERISTICS:
 - INSERTION FORCE: 4.5Kgf MAX.
 - WITHDRAWAL FORCE: 0.5~2.5Kgf.
- LIFE TEST: 5,000 CYCLES
- OTHER GENERAL SPEC. TO REFER "HDMI SERIES SPEC".
- TO CONFORM TO THE SINGATRON HAZARDOUS SUBSTANCE FREE SPEC.
- HALOGEN FREE PRODUCT IDENTIFICATION LABEL ON PACKAGING:
- PACKAGE: SEE "2HE1703-001111F" PACKAGE.
- FOR REFLOW SOLDERING LEAD-FREE PROCESS.

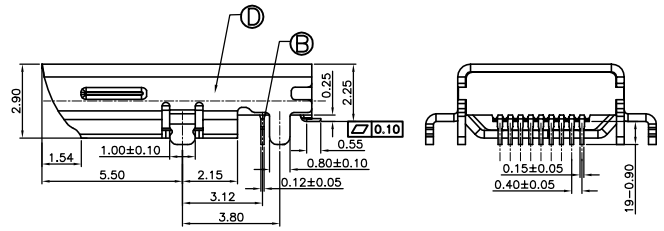
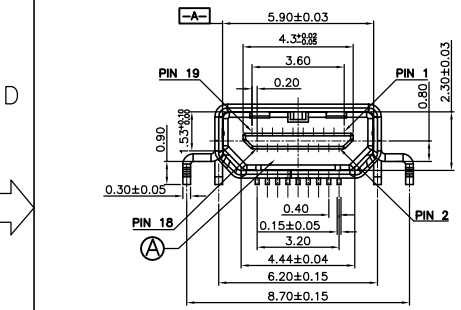

PART NO.
2HE1703-001111F

- SUFFIX: HALOGEN FREE
- PACKAGE: 1: TAPE AND REEL
- HOUSING COLOR: 1: BLACK
- CONTACT PLATING: 1: GOLD FLASH ON CONTACT AREA AND GOLD FLASH ON SOLDER AREA 50u" NICKEL UNDER PLATED

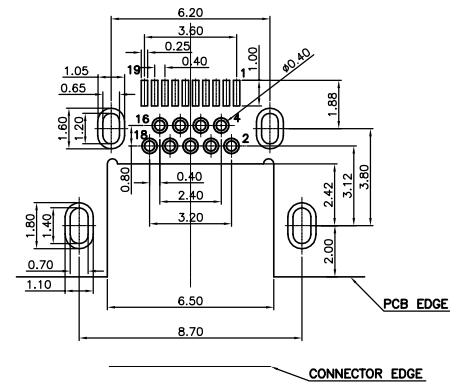
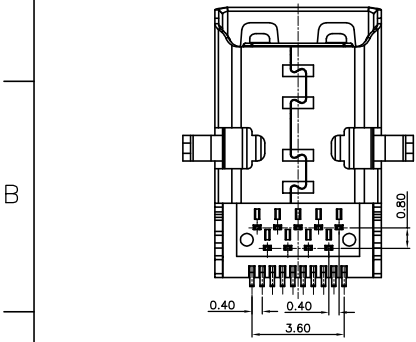

RECOMMENDED PCB LAYOUT(TOP VIEW)
THICKNESS=0.8mm
TOLERANCE UNSPECIFIED=±0.05mm

E	INK		BLACK
D	SHELL	1	STAINLESS STEEL NICKEL
C	SMT CONTACT	10	COPPER ALLOY SEE PART NO.
B	DIP CONTACT	9	COPPER ALLOY SEE PART NO.
A	HOUSING	1	LCP UL 94V-0 BLACK
NO	DESCRIPTION	QTY	MATERIAL PLATING & COLOR

UNLESS OTHERWISE SPECIFIED TOLERANCES		Singatron Enterprise Co., Ltd. 信音企業股份有限公司	
DECIMALS:	ANGLES:	TITLE	HDMI D TYPE FEMALE, DIP, CH=0.80
X :±0.5	X :±2°	DWN	IVY-C 2015.04.29 PART NO. 2HE1703-001111F
X.X :±0.3	X.X :±1°	CHKD	ANGELA 2015.04.29 SCALE 2.5:1 UNIT: mm
X.XX :±0.2		APVD	ANGELA 2015.04.29 SIZE: A3 SHEET: 1 OF 1 REV: A
CUSTOMER COPY			