

DATE CODE:YY MM DD
(YY-YEAR MM-MONTH DD-DAY)

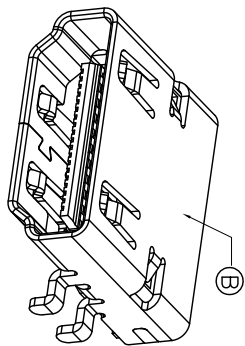

3D VIEW

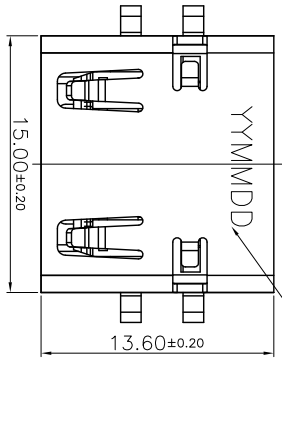
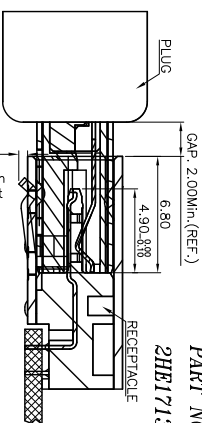
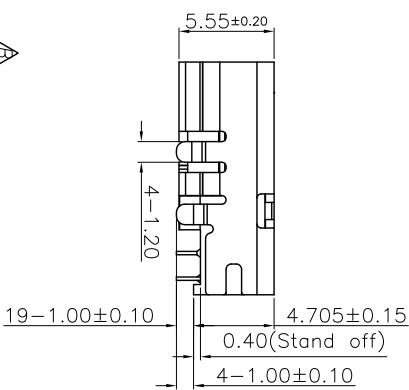
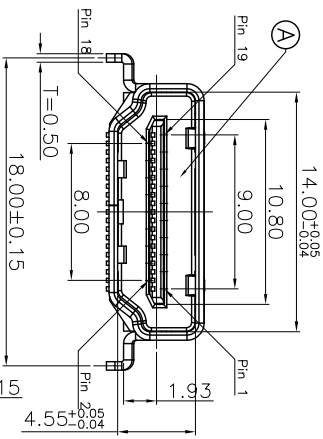

PART NO.

2HE1713-000111F

- SUFFIX: HALOGEN FREE
- PACKAGE 1: TAPE AND REEL
- HOUSING COLOR 1: BLACK
- CONTACT PLATING 1: GOLD FLASH ON CONTACT AREA, GOLD FLASH ON SOLDER AREA, NICKEL UNDERPLATED OVERALL

SPECIFICATIONS:

1. ELECTRICAL CHARACTERISTICS:
 - 1-1. CURRENT RATING: 0.5 AMP.
 - 1-2. VOLTAGE RATING: 40V
 - 1-3. INITIAL CONTACT RESISTANCE EXCLUDING CONDUCTOR RESISTANCE: 10mΩ MAX (TARGET DESIGN VALUE). AFTER TEST: Δ 30mΩ MAX.
 - 1-4. INSULATION RESISTANCE: 100MΩ MIN. @ 500V DC.
 - 1-5. DIELECTRIC WITHSTANDING VOLTAGE: 500V AC FOR 1 MINUTE.
2. MECHANICAL CHARACTERISTICS:
 - 2-1. INSERTION FORCE: 4.5kgf MAX.
 - 2-2. WITHDRAWAL FORCE: 0.7~2.7kgf (INITIAL)
3. LIFE TEST: 10,000 CYCLES.
4. OTHER GENERAL SPEC. TO REFER "HDMI SERIES SPEC."
5. TO CONFORM TO THE SINGATRON HAZARDOUS SUBSTANCE FREE SPEC.
6. HALOGEN FREE PRODUCT IDENTIFICATION LABEL ON PACKAGING:
7. PACKAGE: SEE "2HE1713 SERIES" PACKAGE.
8. FOR REFLOW SOLDERING LEAD-FREE PROCESS.

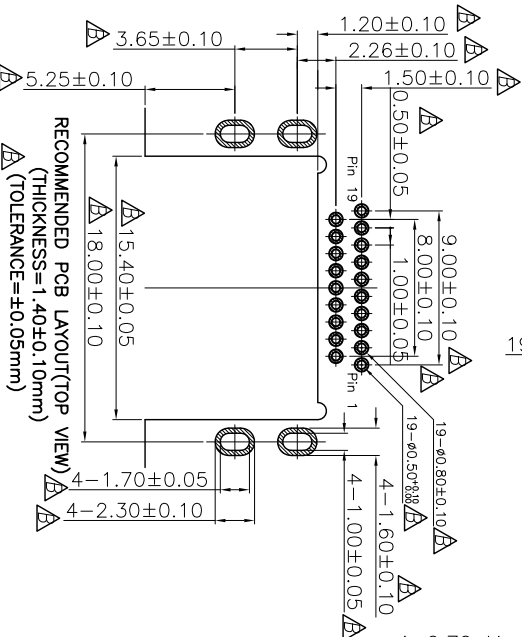
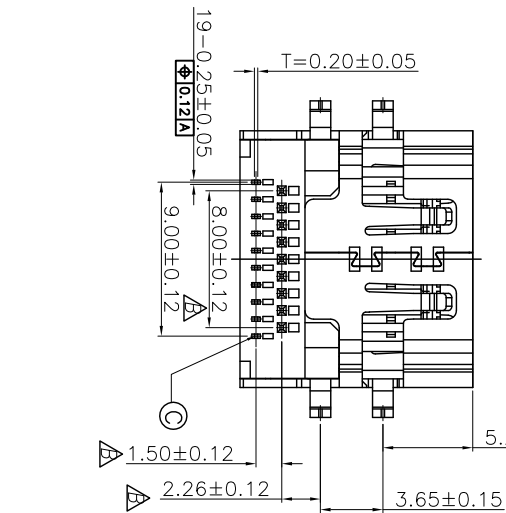

RECOMMENDED PCB LAYOUT(TOP VIEW)
(THICKNESS=1.40±0.10mm)
(TOLERANCE=±0.05mm)

D	INK		BLACK
C	CONTACT	19	COPPER ALLOY
B	SHELL	1	SEE PART NO.
A	HOUSING	1	STAINLESS STEEL
NO	DESCRIPTION	1	NICKEL
			HIGH TEMP. THERMOPLASTIC UL 94V-0
			BLACK
			PLATING & COLOR MATERIAL
UNLESS OTHERWISE SPECIFIED TOLERANCES			
SINGATRON ENTERPRISE CO., LTD. 信管企業股份有限公司			
TITLE: HDMI A TYPE FEMALE, DIP, SINKING, CH=1.93mm			
DWN: IN-C-2014/05/29 PART NO. 2HE1713-000111F			
CHKD: SCALE 1:1 UNIT: mm			
APVD: AME12014/05/29 SIZE: A3 SHEET: 1 OF 1 REV: B			

CUSTOMER COPY

REV.	ECN NO. OR DESCRIPTION	REVISED	DATE
A	PDR RELEASE	IV-C	2014.05.15
B	ECN NO.:140058	IV-C	2014.05.29