

3D VIEW

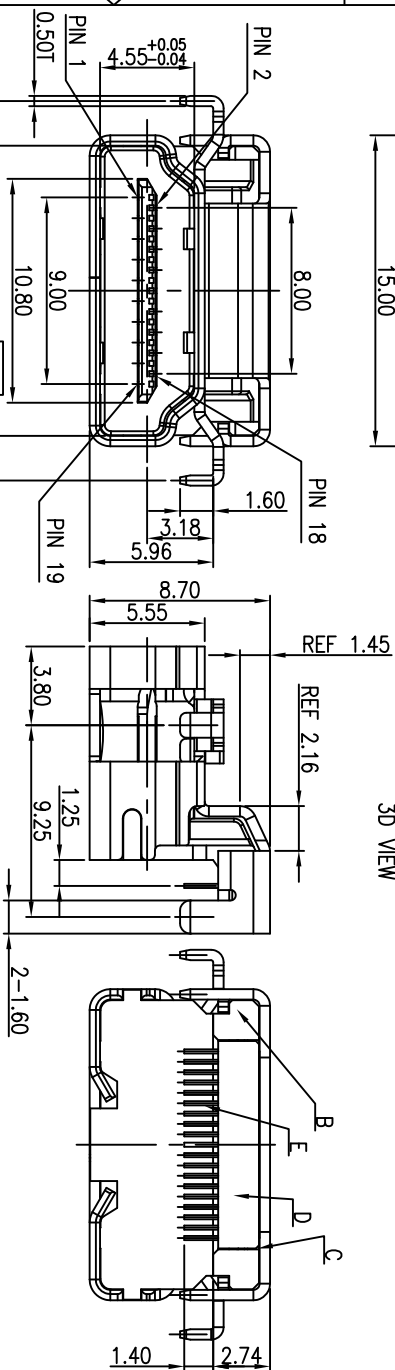

SUFFIX:HALOGEN FREE
 PACKAGE
 1:TAPE & REEL
 HOUSING COLOR
 1:BLACK
 CONTACT PLATING
 CONTACT AREA: 5u" GOLD

- SPECIFICATIONS:
- ELECTRICAL CHARACTERISTICS:
 - CURRENT RATING: 0.5A
 - VOLTAGE RATING: 40V
 - CONTACT RESISTANCE: 10mohm MAX.(INITIAL)
 - DIELECTRIC WITHSTANDING VOLTAGE: 300V AC FOR ONE MINUTE
 - INSULATION RESISTANCE: 100Mohm MIN. MEASURED BY 500V DC
 - MECHANICAL CHARACTERISTICS:
 - INSERTION FORCE : 4.5KGF MAX.
 - WITHDRAWAL FORCE : 1.0~4.0 KGF
 - LIFE TEST: 10,000 CYCLES.
 - OTHER GENERAL SPEC. TO REFER "ZHE3Y10-000111F" SPEC."
 - TO CONFORM TO SINGATRON HAZARDOUS SUBSTANCE FREE SPEC.
 - HALOGEN FREE PRODUCT IDENTIFICATION LABEL ON PACKAGING.
 - FOR REFLOW SOLDERING LEAD-FREE PROCESS.
 - PART NO.: ZHE3Y10-000111F

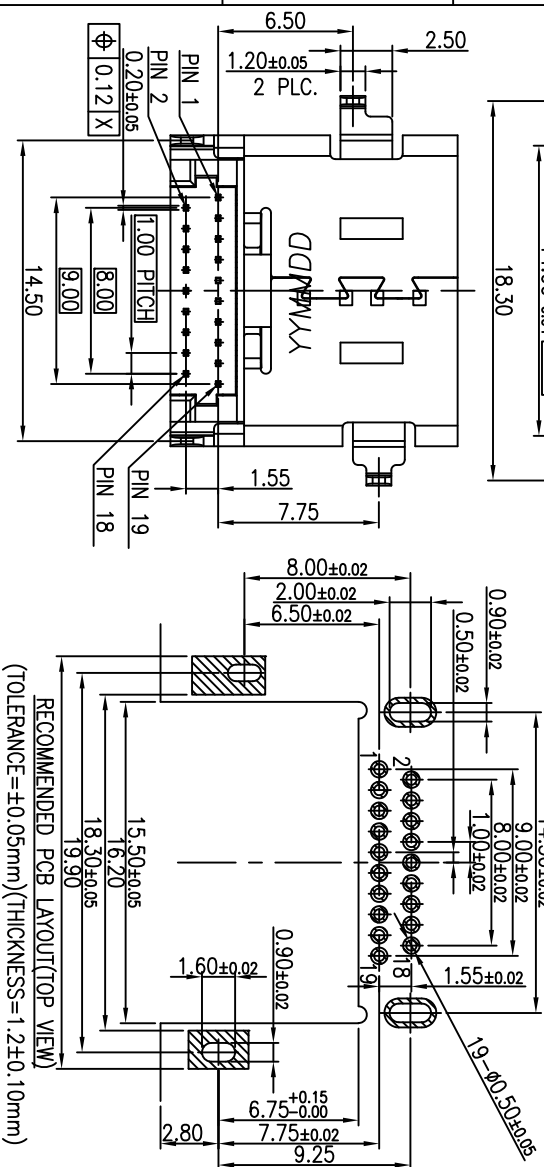

E	TERMINAL	19	COPPER ALLOY, T=0.20	SOLD 5u" ON CONTACT AREA WASTE 7IN 80u" MIN ON SOLDER TAIL ALL OVER NICKEL 50u" MIN.
D	BOTTOM COVER	1	HIGH TERP.	
C	TOP COVER	1	THERMOPLASTIC, HF, UL94V-0	BLACK
B	HOUSING	1		
A	SHELL	1	STAINLESS STEEL,T=0.50	NICKEL 50~100u"
NO	DESCRIPTION	QTY	MATERIAL	PLATING & COLOR
UNLESS OTHERWISE SPECIFIED TOLERANCES				
Singatron Enterprise Co., Ltd. 信營企業股份有限公司				
TITLE: HDMI FEMALE REVERSE BY DIP TYPE, CH=3.18				
DWG: Soldier PART NO: ZHE3Y10-000111F				
CHKD: James SCALE: 4:1 UNIT: mm				
APVD: Quon SIZE: A3 SHEET: 1 OF 1 REV: A				
CUSTOMER COPY				