

REV.	ECN NO. OR DESCRIPTION	REVISED	DATE
A	PDR NO:171227-1A	Chensong	2018.08.20

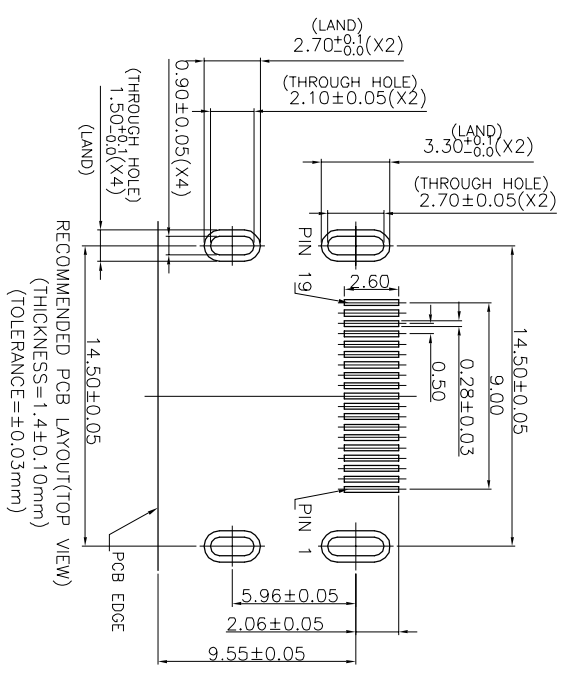

- SPECIFICATIONS:
- ELECTRICAL CHARACTERISTICS:
 - CURRENT RATING: 0.5 AMP.
 - VOLTAGE RATING: 40V.
 - CONTACT RESISTANCE: 10mΩ MAX.
 - INSULATION RESISTANCE: 100MΩ MIN. AT 300V DC.
 - DIELECTRIC WITHSTANDING VOLTAGE: 300V AC FOR 1 MINUTE.
 - MECHANICAL CHARACTERISTICS:
 - INSERTION FORCE: 4.5kgf MAX.
 - WITHDRAWAL FORCE: 0.5~4.0kgf.
 - LIFE TEST: 5,000 CYCLES.
 - OTHER GENERAL SPEC. TO REFER "HDMI A TYPE RECEPTACLE SERIES SPEC."
 - TO CONFORM TO THE SINGATRON HAZARDOUS SUBSTANCE FREE SPEC.
 - HALOGEN FREE PRODUCT IDENTIFICATION LABEL ON PACKAGING.
 - FOR REFLOW SOLDERING LEAD-FREE PROCESS.
 - PACKAGE: TAPE & REEL.

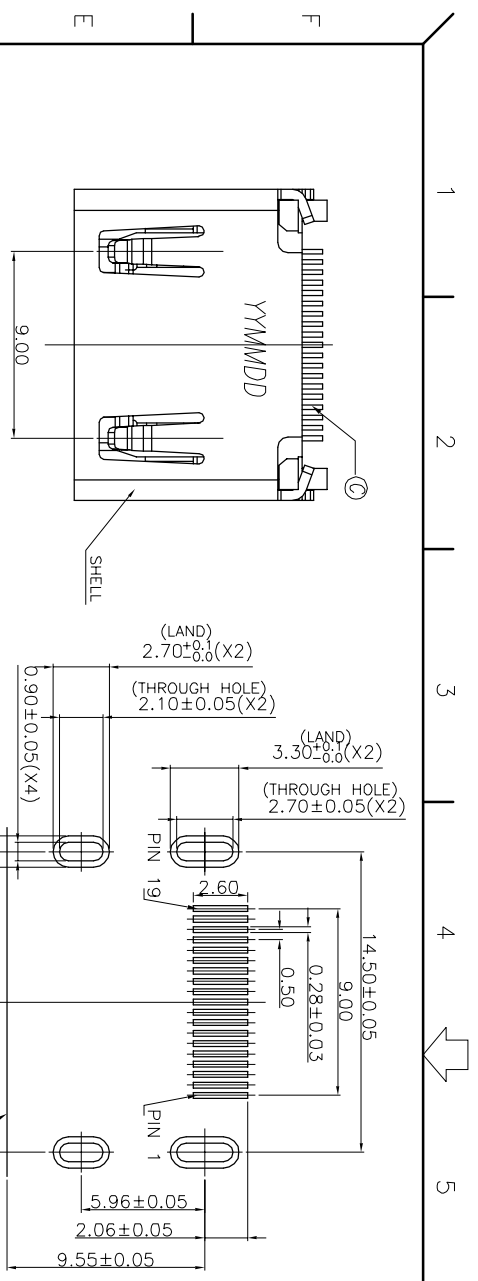
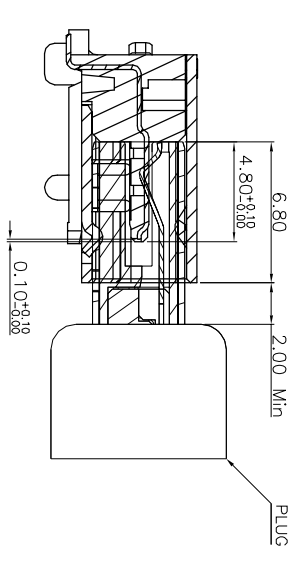
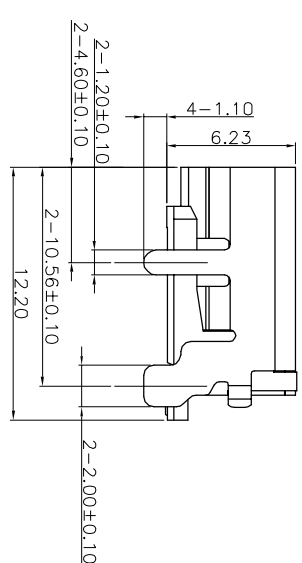
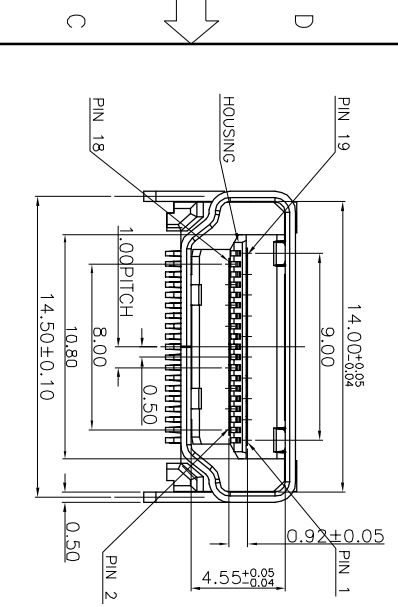

PLUG INSERTION DEPTH

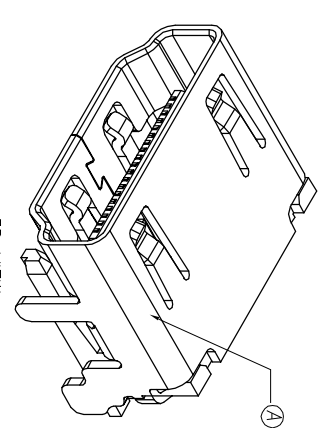
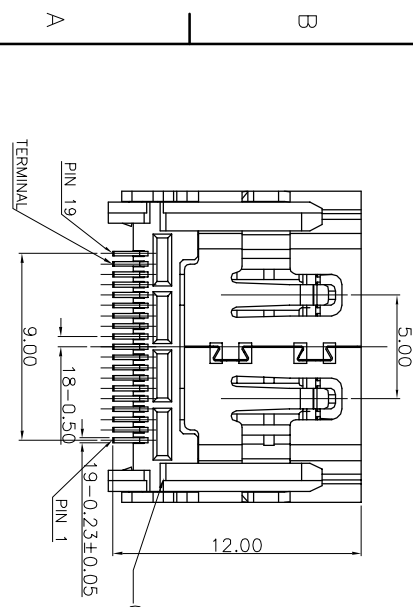

3D VIEW

C	CONTACT	19	C2680, T=0.20	GOLD FLASH ON CONTACT AREA; WHITE TIN 80μ" ON SOLDER AREA; ALL OVER IN 300 μM.
B	HOUSING	1	LCP E130I+30%G.F.	BLACK
A	SHELL	1	C2680, T=0.50	NICKEL 50~100μ"
NO	DESCRIPTION	QTY	MATERIAL	PLATING & COLOR
UNLESS OTHERWISE SPECIFIED TOLERANCES				
Singatron Enterprise Co., Ltd. 信音企業股份有限公司				
DECIMALS:		ANGLES:		
X	:±0.5	X	:±2°	
X.X	:±0.3	X.X	:±1°	
X.XX	:±0.2			
TITLE HDMI A TYPE FEMALE SMT TYPE				
DWN	Chensong	PART NO.	ZHE3Y13-003111F	
CHKD		SCALE	4:1	UNIT: mm
APVD		SIZE:	A3	SHEET: 1 OF 1
REV: A				

CUSTOMER COPY