

| REV/ECN NO OR DESCRIPTION | REVISED | DATE |
|---------------------------|---------|------------|
| A PDR NO.: T120706-7A | KUREN | 2013.07.10 |

SPECIFICATIONS:

- 1. ELECTRICAL CHARACTERISTICS:**
 1-1. CURRENT RATING: 0.5A
 1-2. VOLTAGE RATING: 40V
 1-3. CONTACT RESISTANCE: 10mohm MAX.
 1-4. DIELECTRIC WITHSTANDING VOLTAGE: 300V AC FOR ONE MINUTE (MATED CONNECTOR)
 1-5. INSULATION RESISTANCE: 100Mohm MIN. MEASURED BY 500V DC (UNMATED CONNECTOR)
- 2. MECHANICAL CHARACTERISTICS:**
 2-1. INSERTION FORCE : 4.5KGf MAX.
 2-2. WITHDRAWAL FORCE : 1.0~4.0 KGf
3. LIFE TEST: 5,000 CYCLES.
 4. OTHER GENERAL SPEC. TO REFER "2HE3Y24-000111F SPEC".
 5. TO CONFORM TO SINGATRON HAZARDOUS SUBSTANCE FREE SPEC.
 6. HALOGEN FREE PRODUCT IDENTIFICATION LABEL ON PACKAGING.
 7. FOR REFLOW SOLDERING LEAD-FREE PROCESS.

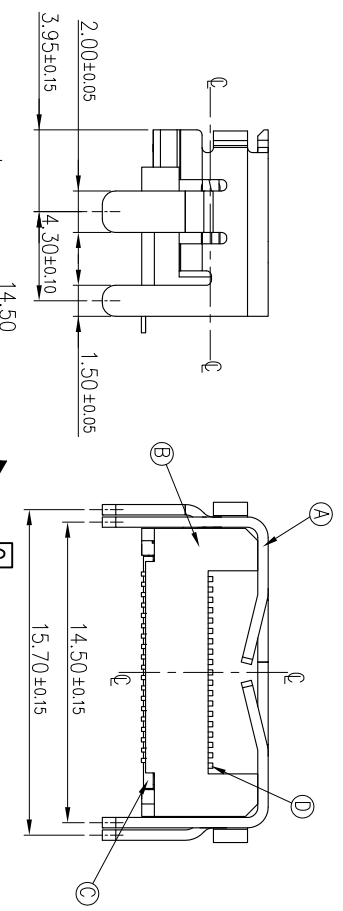
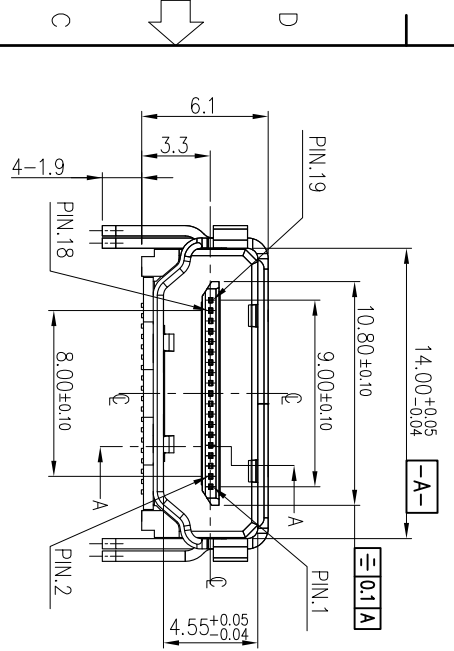
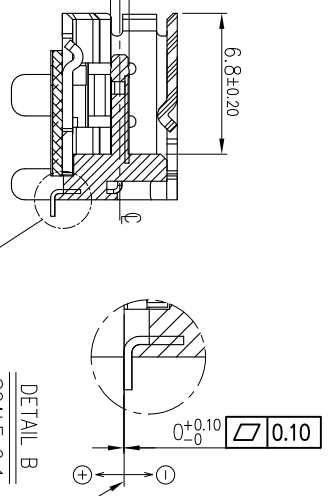
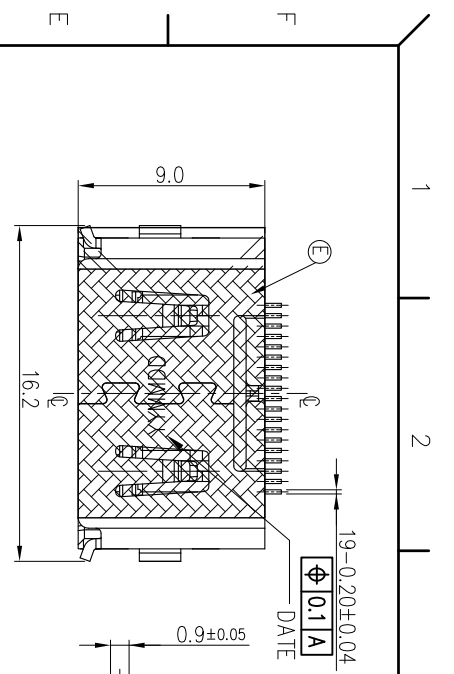

PLUG MATING REFERENCE

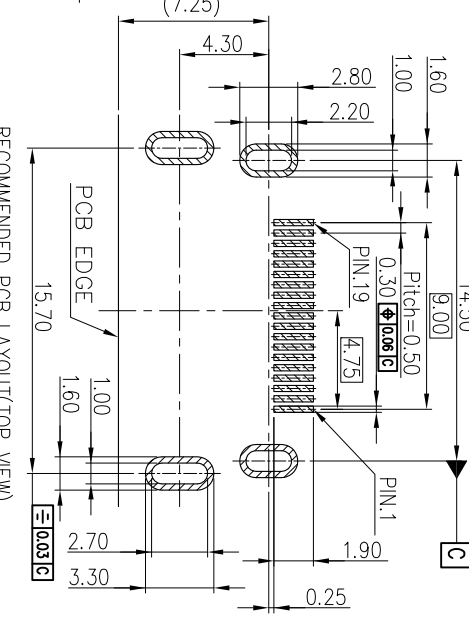
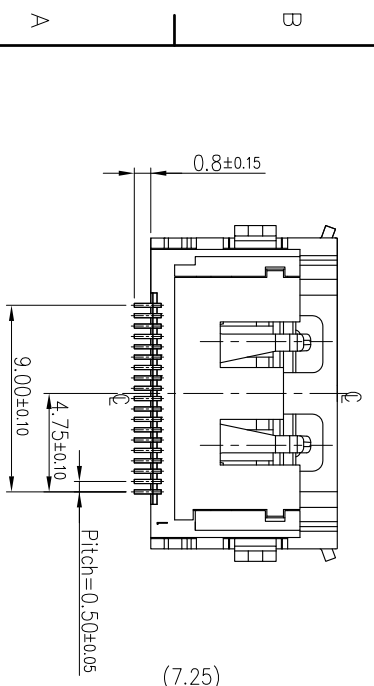
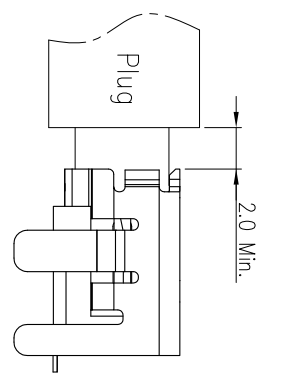

RECOMMENDED PCB LAYOUT(TOP VIEW)
 THICKNESS=1.2~1.6mm TOLERANCE=±0.05mm

| | | | | |
|----|-------------|-----|---------------------------------|----------------------------|
| E | MYLAR | 1 | L12*W9.0 | YELLOW |
| D | TERMINAL | 19 | BRASS T=0.20 | GOLD FLASH ON CONTACT AREA |
| C | COVER | 1 | HIGH TEMP THERMOPLASTIC J194-V0 | BLACK |
| B | BODY | 1 | HIGH TEMP THERMOPLASTIC J194-V0 | BLACK |
| A | SHELL | 1 | BRASS T=0.50 | 50U" MIN NI |
| NO | DESCRIPTION | QTY | MATERIAL | PLATING & COLOR |

UNLESS OTHERWISE SPECIFIED TOLERANCES
 Singatron Enterprise Co., Ltd.
 信營企業股份有限公司

| | | | |
|---------------|-----------|-------|--|
| DECIMALS: | ANGLES: | TITLE | HDMI A TYPE RECEPTACLE CONNECTOR (FOXCONN) |
| X : ±0.5 | X : ±2° | DMW | KUREN |
| X.X : ±0.3 | X.X : ±1° | CHKD | SOLDER |
| X.XX : ±0.2 | | APVD | BOYE |
| CUSTOMER COPY | | | |