

| | | | |
|------|-----------------------|---------|------------|
| REV. | ECN NO OR DESCRIPTION | REVISED | DATE |
| A | PDR RELEASE | EVEN | 2020.12.29 |
| B | ECN NO: L202101-C07 | EVEN | 2021.03.16 |

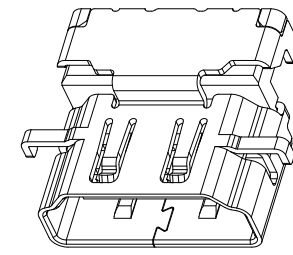

- SPECIFICATIONS: (HDMI A TYPE)
- ELECTRICAL CHARACTERISTICS:
 - CURRENT RATING: 0.5 AMP.
 - VOLTAGE RATING: 40V.
 - INITIAL CONTACT RESISTANCE EXCLUDING CONDUCTOR RESISTANCE: 10mΩ MAX. (TARGET DESIGN VALUE). AFTER TEST: Δ30mΩ MAX.
 - INSULATION RESISTANCE: 100MΩ MIN. @ 500V DC.
 - DIELECTRIC WITHSTANDING VOLTAGE: 500V AC FOR 1 MINUTE.
 - MECHANICAL CHARACTERISTICS:
 - INSERTION FORCE: 4.5Kgf MAX.
 - WITHDRAWAL FORCE: 1.0~4.0Kgf.
 - LIFE TEST: 10,000 CYCLES.
 - OTHER GENERAL SPEC. TO REFER "2HE3Y58-200211F SPEC".
 - TO CONFORM TO THE SINGATRON HAZARDOUS SUBSTANCE FREE SPEC.
 - HALOGEN FREE PRODUCT IDENTIFICATION LABEL ON PACKAGING:
 - PACKAGE: SEE "2HE3Y58-200211F" PACKAGE.
 - FOR REFLOW SOLDERING LEAD-FREE PROCESS.

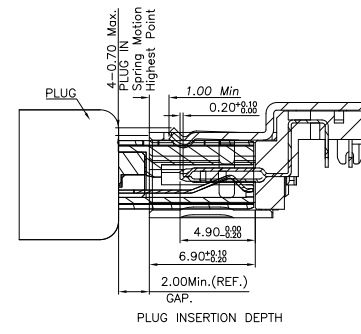
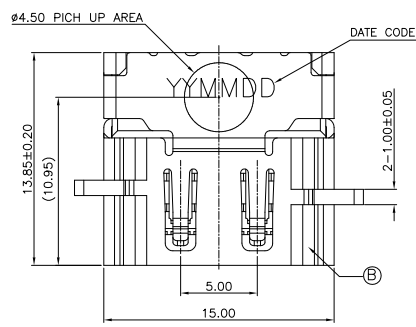
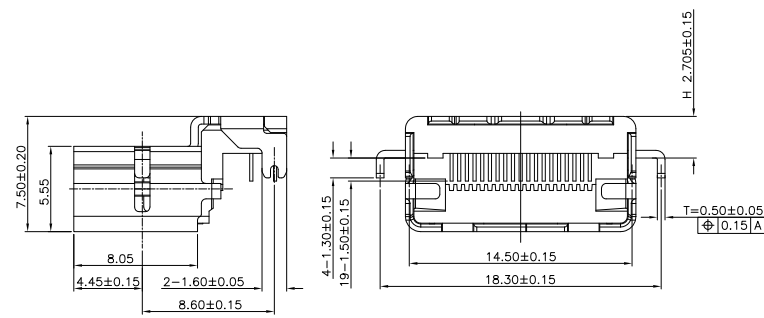
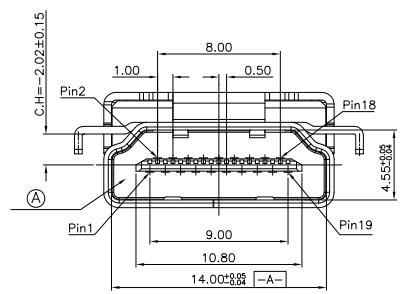

PART NO.
2HE3Y58-200211F

- SUFFIX: HALOGEN FREE
- PACKAGE: 1: TAPE AND REEL
- HOUSING COLOR: 1: BLACK
- CONTACT PLATING: 2: GOLD FLASH(Au 1u") ON CONTACT AREA, 60u~150u". MATTE TIN ON SOLDER AREA 50u" MIN. NICKEL UNDERPLATE OVER ALL.

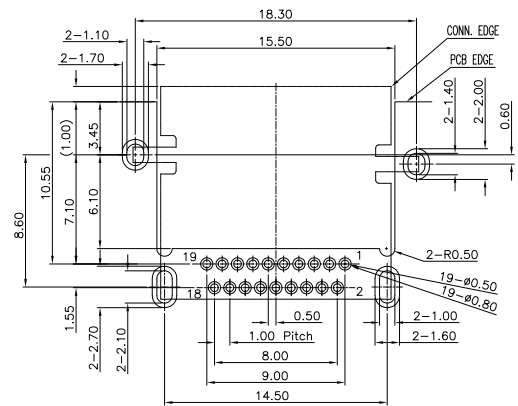
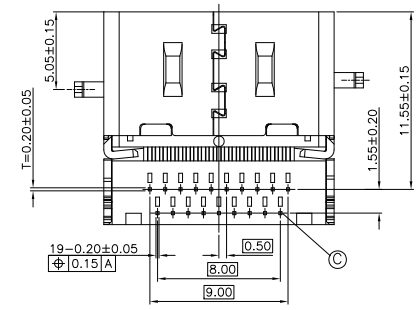

RECOMMENDED PCB LAYOUT(TOP VIEW)
(TOLERANCE=±0.03mm)
(PCB THICKNESS=1.0±0.05mm)

| | | | | |
|----|-------------|-----|--------------|------------------|
| C | CONTACT | 19 | C2680 | SEE PART NO. |
| B | SHELL | 1 | SUS304 | 50u" MIN. NICKEL |
| A | HOUSING | 1 | LCP UL 94V-0 | BLACK |
| NO | DESCRIPTION | QTY | MATERIAL | PLATING & COLOR |

| | | | | |
|---------------------------------------|-----------|--------------|---|-------------------------------|
| UNLESS OTHERWISE SPECIFIED TOLERANCES | | 信音科技(香港)有限公司 | | |
| DECIMALS: | ANGLES: | TITLE | HDMI A TYPE FEMALE, REVERSE, DIP TYPE C.H=-2.02mm | |
| X : ±0.5 | X : ±2° | DWN | EVEN 2021.03.16 | PART NO. 2HE3Y58-200211F |
| X.X : ±0.3 | X.X : ±1° | CHKD | SCALE 3.7:1 | UNIT: mm |
| X.XX : ±0.2 | | APVD | ANGELA2021.03.16 | SIZE: A3 SHEET: 1 OF 1 REV: B |
| CUSTOMER COPY | | | | |