

REV.	ECN NO OR DESCRIPTION	REVISED	DATE
A	PDR NO:S160121-8A	jttlucky	2016.05.05

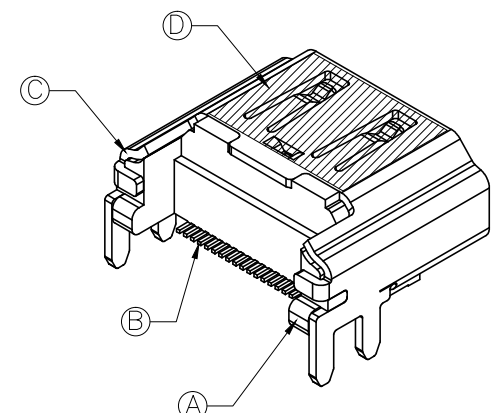

SPECIFICATIONS:

- Contact current Rating:
1.5 Amperes
Dielectric Withstanding Voltage:AC 150V(RMS)
Insulation resistance:500Megohms Minimum.
- Contact Resistance:
30mΩ Max
50mΩMax for other contacts
- Mechanical Characteristics:
Mating Force:45 Newtoms.Maximum
Unmating Force:10 Newtoms.Minimum.
- OTHER GENERAL SPEC. TO REFER "2HE3Y73-000111F_SPEC".
- TO CONFORM TO SINGATRON HAZARDOUS SUBSTANCE FREE SPECIFICATION
- HALOGEN PRODUCT IDENTIFICATION LABEL ON PACKAGING:
- PACKAGING:TAPE&REEL

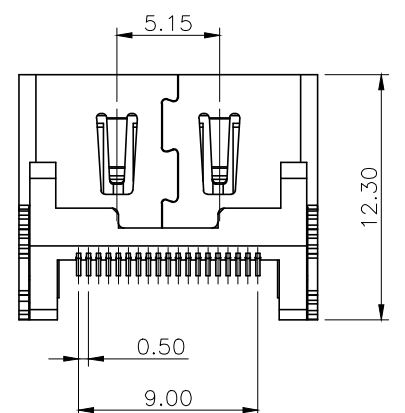
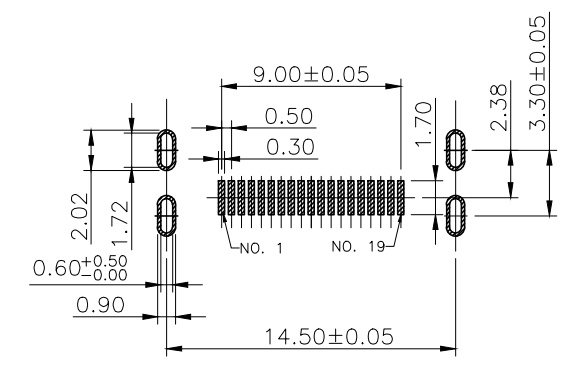
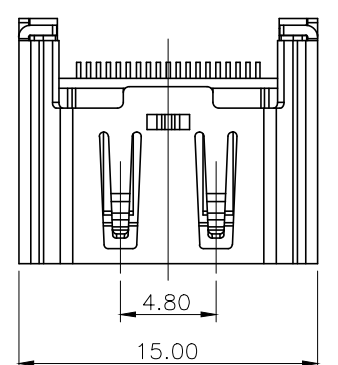
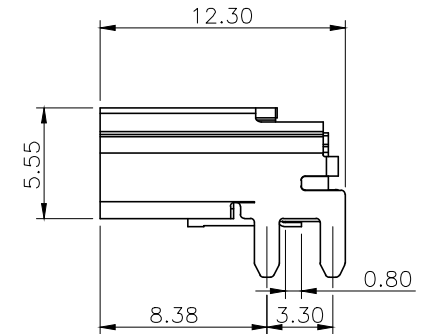
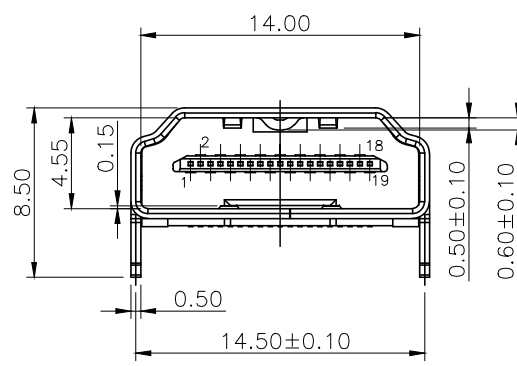

D	MYLAR	1	PET Transparent	L10*W7.8*H0.05(Max)
C	SHELL	2	BRASS T=0.50mm	OVER BRIGHT Ni 50u"MIN.
B	CONTACT	19	PHOSPHOR BRONZE T=0.20mm	Au 1U" PLATING ON CONTACT AREA; 100u" MIN. MATTE TIN PLATING ON SOLDERTAILS; 50u" MIN. NICKEL UNDER PLATING OVERALL ;
A	HOUSING	1	LCP +30% G.F UL 94V-0	BLACK
NO	DESCRIPTION	QTY	MATERIAL	PLATING & COLOR

UNLESS OTHERWISE SPECIFIED TOLERANCES		Singatron Enterprise Co., Ltd. 信音企業股份有限公司		
DECIMALS:	ANGLES:	TITLE	HDMI CONN. RESERVE SMT TYPE, 19POS.	
X :±0.5	X :±2°	DWN	jttlucky	PART NO.2HE3Y73-000111F
X.X :±0.3	X.X :±1°	CHKD	JAMES	SCALE:4:1 UNIT: mm
X.XX :±0.2		APVD	BOYE	SIZE: A3 SHEET:1 OF 1 REV: A
CUSTOMER COPY				