

REV	ZONE	REVISION	DATE

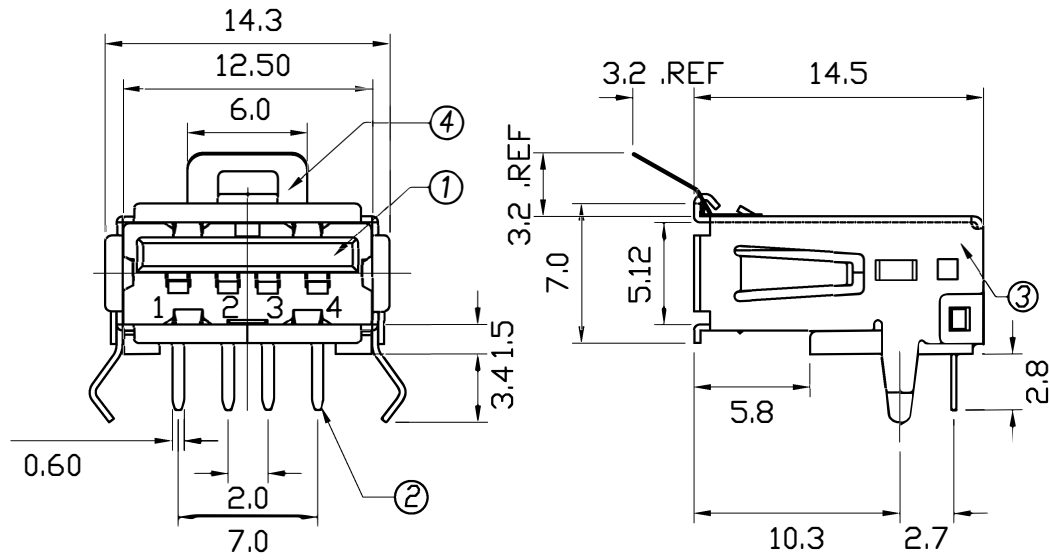

Specification:
 Contact Resistance: 30m Ohm Max.
 Insulation Resistance: 1000M Ohm Min. At 500VDC.
 Rated Voltage And Current: 1.5A At 250VAC Minimum.
 Dielectric Withstanding Voltage:
 750V AC (rms) for 1 Minute(Rev. 1.1)
 Durability (Life Test): 1500 Cycles
 Insertion Force: 35 Newton Maximum.
 Extraction Force: 10 Newton Minimum.

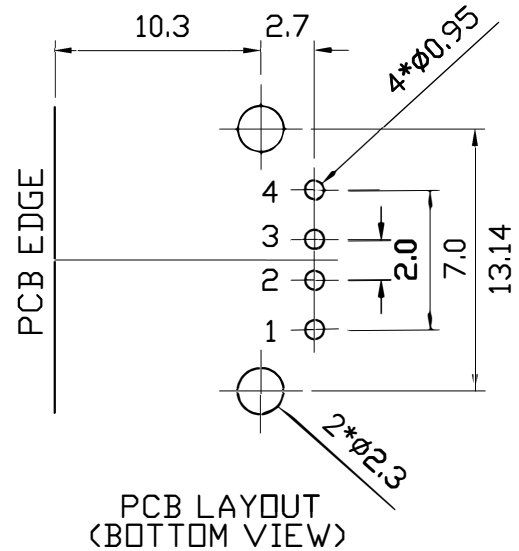

Green Product

NO.	NAME	MATERIAL	FINISH	Q'TY	REMARK
1	HOUSING	PBT G.F.	BLACK	1	
2	TERMINAL	PHOS. BRONZE T:0.25	GOLD/TIN PLATED	4	Gold:1~3u"; Ni:40~60u"; TIN:120u" (100% pure Tin of lead free plating)
3	SHELL	BRASS T:0.3	NICKEL PLATED	1	Ni:80~120u"
4	SPRING SHIELD	STAINLESS	THK:0.1	1	

SINGATRON U.S.A.

COMPUTER NO.			UNIT	SCALE	PART NAME	
D:\DWG\2KS-001SANBOL			mm	1:1	USB A TYPE FLAT 4 PIN DIP	
APPD.	CKD.	DWG.	DATE	TOLERANCE	PART NO.	REV.
		TINA	15-09-10	X. ±0.38 .X ±0.25 .XX ±0.13 .XXX ±0.05	2KS-001SANBOL	A0

MODEL 2KS-001SANBOL PAGE 1 OF 1