

REV.	ECN NO.	OR DESCRIPTION	REVISED	DATE
A	PDR NO: T120224-8A	Horlen	2012.7.20	
B	ECN NO: S130608	Horlen	2013.6.5	
C	ECN NO: S140947	YF	2014.09.19	

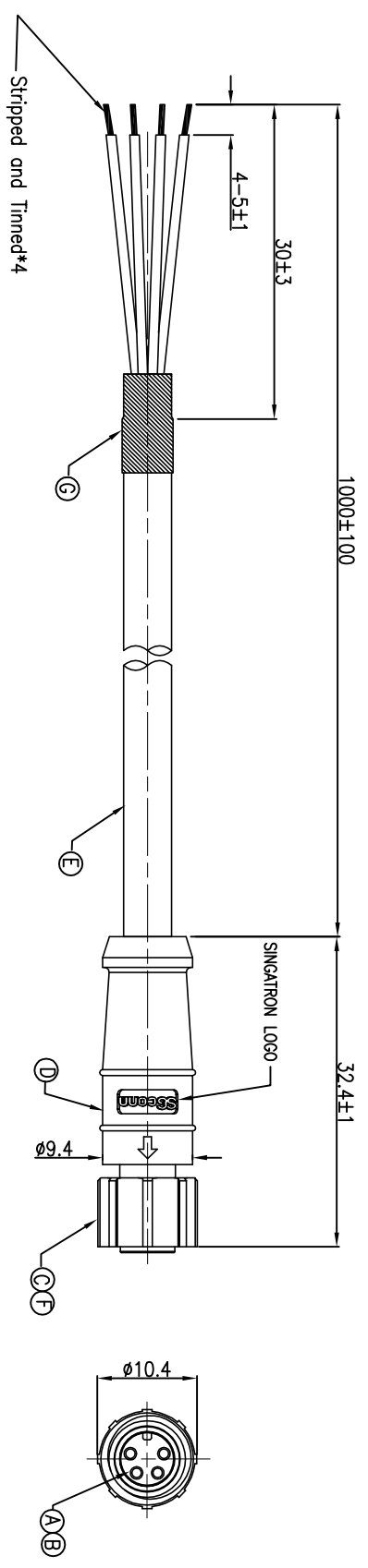

WIRE COLOR	CONN.
BLUE	4
GREEN	3
BLACK	2
RED	1

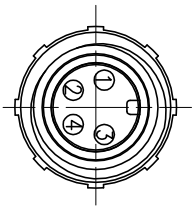

PIN ASSIGNMENTS
FRONT VIEW

NOTES:

1. WATERPROOF RATE: IP67
IP67: IMMERSED IN 1M WATER FOR 30 MINUTES
2. ELECTRICAL CHARACTERISTICS
TEMPERATURE RANGE: -20°C TO +80°C
RATING: 60V AC/DC 5A
DIELECTRIC WITHSTANDING VOLTAGE: 500V AC FOR ONE MINUTE
3. SPECIFICATIONS: SEE "M8 SERIES SPECIFICATIONS".
4. TO CONFORM TO SINGATRON HAZARDOUS SUBSTANCE FREE SPEC.
5. GREEN PRODUCT IDENTIFICATION LABEL ON PACKAGING: Gr. Pass

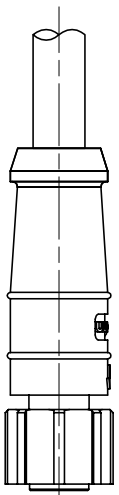

1 2 3 4 5 6 7 8

NO	DESCRIPTION	QTY	MATERIAL	PLATING & COLOR
A	BODY	1	TPU	BLACK
B	FEMALE PIN	4	Phosphor Bronze	6u" GOLD PLATING OVER NICKEL PLATING
C	NUT	1	NYLON+GF	BLACK
D	OVER MOLD	1	TPU	BLACK
E	CABLE	1	UL2464 22AWG*4C+AL+D +B 0D:6.0(UV)	BLACK(PVC JACKET)
F	O-RING	1	VITON	RED
G	HEAT SHRINK TUBE	1	φ6.0 125' 300V L:15	BLACK

UNLESS OTHERWISE SPECIFIED TOLERANCES
DECIMALS: ANGLES:
X :±0.5 X :±2
X.X :±0.3 X.X :±1'
X.XX :±0.2

 Singatron Enterprise Co., Ltd.
信晉企業股份有限公司

TITLE: M8 SERIES FEMALE CONN. (4PIN)
DWG YF PART NO. 2M83010-W04303H
CHKD JF SCALE 2:1 UNIT: mm
APVD Horlen SIZE: A3 SHEET: 1 OF 1 REV: C

CUSTOMER COPY