

REV.	ECN NO.	OR DESCRIPTION	REVISION	DATE
A	PDR NO. IT150109-7B	Vicky		2015.01.12
B	ECN NO. S150904-R	Vicky		2015.09.02

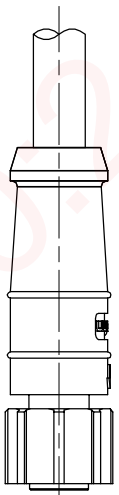

WIRE COLOR	CONN.
WHITE	4
GREEN	3
RED	2
BLACK	1

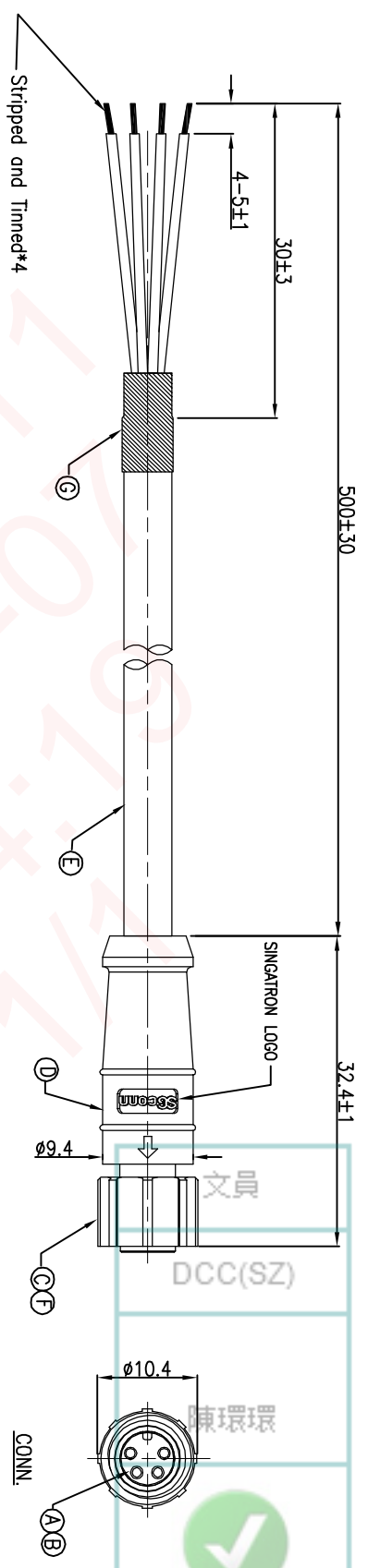
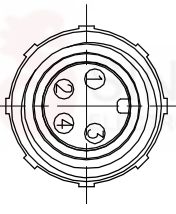

PIN ASSIGNMENTS
FRONT VIEW

NOTES:

1. WATERPROOF RATE: IP67
IP67: IMMERSED IN 1M WATER FOR 30 MINUTES
2. ELECTRICAL CHARACTERISTICS
TEMPERATURE RANGE: -20°C TO +80°C
RATING: 60V AC/DC 5A
3. SPECIFICATIONS: SEE "M8 SERIES SPECIFICATIONS".
DIELECTRIC WITHSTANDING VOLTAGE: 500V AC FOR ONE MINUTE
4. TO CONFORM TO SINGATRON HAZARDOUS SUBSTANCE FREE SPEC.
5. GREEN PRODUCT IDENTIFICATION LABEL ON PACKAGING: **GREEN PASS**

NO	DESCRIPTION	QTY	MATERIAL	PLATING & COLOR
A	BODY	1	TPU	BLACK
B	FEMALE PIN	4	Phosphor Bronze	6μ" GOLD PLATING OVER NICKEL PLATING
C	NUT	1	NYLON+GF	BLACK
D	OVER MOLD	1	TPU	BLACK
E	CABLE	1	UL2095 20AWG*4C+AL+D +B OD=05.5(VV)	BLACK(PVC JACKET)
F	0-RING	1	VITON	RED
G	HEAT SHRINK TUBE	1	φ6.0 125' 300V L:1:5	BLACK

UNLESS OTHERWISE SPECIFIED TOLERANCES

DECIMALS: ANGLES:

X :±0.5 X :±2
X.X :±0.3 X.X :±1'
X.XX :±0.2

Singatron Enterprise Co., Ltd.
信譽企業股份有限公司

TITLE: M8 SERIES FEMALE CONN. (4PIN)

DWN Vicky PART NO. 2M83010-W04317H
CHKD Harlen SCALE 2:1 UNIT: mm
APVD Steve SIZE: A3 SHEET: 1 OF 1 REV: B

CUSTOMER COPY