

REV.	ECN NO.	OR	DESCRIPTION	REVISED	DATE
A	PDR NO:S150429-2A			Lin	2015.04.28

 2015/12/28
 5:21:24

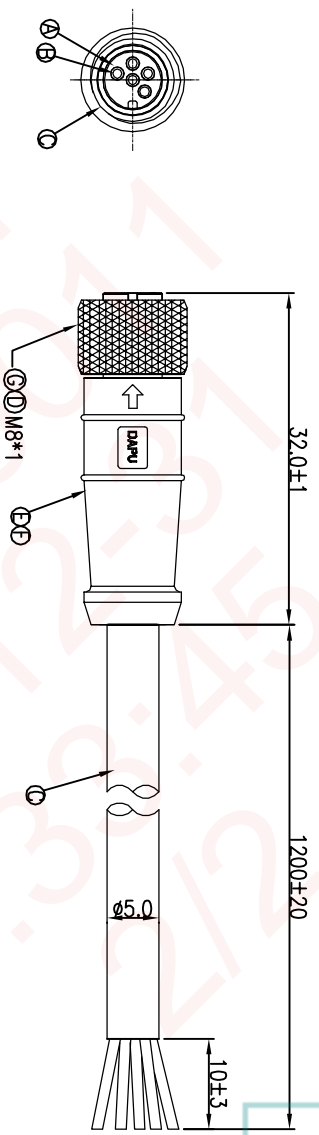

5	BLACK
4	RED
3	WHITE
2	GRAY
1	YELLOW
CONN.	WIRE COLOR

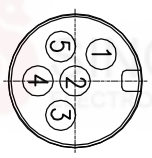

Pin Assignments
Front View

- NOTES:
- ELECTRICAL CHARACTERISTICS:
 - 1-1 CURRENT RATING: 2 AMPS
 - 1-2 CONTACT RESISTANCE: 3 Ohm Max.
 - 1-3 INSULATION RESISTANCE: 100 Mohm Min. at 500VDC
 - 1-4 BREAKDOWN VOLTAGE: 500 VAC PER MINUTE
 - MECHANICAL CHARACTERISTICS:
 - 2-1 TIGHTENING TORQUES: 0.6~0.8nm(5.3~7.0lbs.in)
 - ENVIRONMENTAL:
 - 3-1 OPERATING TEMPERATURE: -20° TO +80°
 - 3-2 SEALING REQUIREMENTS: IP65
 - 4. LIFE TEST: 1,000 CYCLES MIN.
 - OTHER GENERAL SPEC. TO REFER "M8 SERIES GENERAL SPEC".
 - FOR TECHNICAL DATA REFER TO YOUR LOCAL SINGATRON ELECTRONICS SALES OFFICE
 - ALL DIMENSIONS ARE NOMINAL FOR REFERENCE ONLY UNLESS OTHERWISE STATED
 - TO CONFORM TO SINGATRON HAZARDOUS SUBSTANCE FREE SPEC
 - GREEN PRODUCT IDENTIFICATION LABEL ON PACKAGING SEAL (PDR: P448)

NO	DESCRIPTION	QTY	MATERIAL	PLATING & COLOR
A	BODY	1	PPE	BLACK
B	FEMALE PIN	5	COPPER ALLOY	1~3u" GOLD FLASH OVER NICKEL PLATING
C	CABLE	1	UL2464 24#*5C 0D5.0	BLACK(PVC JACKET)
D	NUT	1	BRASS	NICKEL PLATING
E	OVER MOLD	1	TPU	BLACK
F	SHRINK TUBE	5	ø1.5*7mm	BLACK
G	0-RING	1	VITON	RED

UNLESS OTHERWISE SPECIFIED TOLERANCES

DECIMALS:	ANGLES:
X :±0.5	X :±2°
X.X :±0.3	X.X :±1°
X.XX :±0.2	

 Singatron Enterprise Co., Ltd.
 信亨企業股份有限公司
 TITLE: M8 SERIES SPIN FEMALE CONNECTOR, PVC CABLE
 DWN Lin PART NO. 2ME3010-W05238H
 CHKD Horten SCALE 2:1 UNIT: mm
 APVD Steve SIZE: A3 SHEET: 1 OF 1 REV: A
CUSTOMER COPY