

REV.	ECN NO.	OR DESCRIPTION	REVISED	DATE
A	PDR NO:S150706-7A	Blues	2015.07.28	

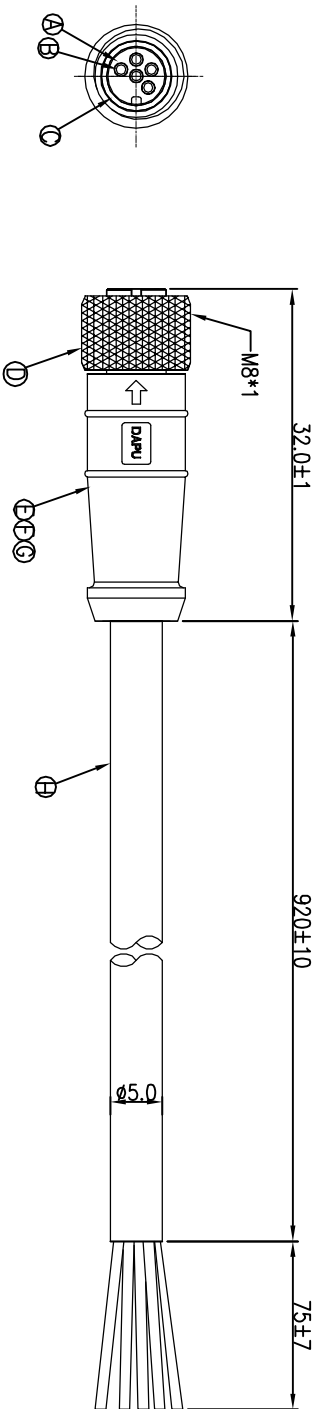

5	BLACK
4	RED
3	WHITE
2	GRAY
1	YELLOW
CONN.	WIRE COLOR

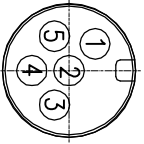

Pin Assignments  
Front View

- NOTES:
- ELECTRICAL CHARACTERISTICS:
    - CURRENT RATING: 2 AMPS
    - CONTACT RESISTANCE: 3 Ohm Max.
    - INSULATION RESISTANCE: 100 Mohm Min. at 500VDC
    - BREAKDOWN VOLTAGE: 500 VAC PER MINUTE
  - MECHANICAL CHARACTERISTICS:
    - TIGHTENING TORQUES: 0.6~0.8Nm(5.3~7.0lbs.in)
  - ENVIRONMENTAL:
    - OPERATING TEMPERATURE: -20° TO +80°
    - SEALING REQUIREMENTS: IP65
    - LIFE TEST: 1,000 CYCLES MIN.
  - OTHER GENERAL SPEC. TO REFER "M8 SERIES GENERAL SPEC".
  - FOR TECHNICAL DATA REFER TO YOUR LOCAL SINGATRON ELECTRONICS SALES OFFICE
  - ALL DIMENSIONS ARE NOMINAL FOR REFERENCE ONLY UNLESS OTHERWISE STATED
  - TO CONFORM TO SINGATRON HAZARDOUS SUBSTANCE FREE SPEC
  - GREEN PRODUCT IDENTIFICATION LABEL ON PACKAGING SEAL

H	CABLE	1	UL2464 24#*SC (UV)	BLACK(PVC JACKET)
G	SHRINK TUBE	5	125' 300V Ø1.5	BLACK
F	OVER MOLD	1	TPU	BLACK
E	INNER MOLD	1	TPU	BLACK
D	NUT	1	BRASS	NICKEL PLATING
C	O-RING	1	VITON	RED
B	FEMALE PIN	5	Phosphor bronze	1~3µ" GOLD FLASH OVER NICKEL PLATING
A	BODY	1	PPE	BLACK
NO	DESCRIPTION	QTY	MATERIAL	PLATING & COLOR

UNLESS OTHERWISE SPECIFIED TOLERANCES

DECIMALS: ANGLES:

X :±0.5 X :±2°  
 X.X :±0.3 X.X :±1°  
 X.XX :±0.2

Singatron Enterprise Co., Ltd.  
 信亨企業股份有限公司

TITLE: M8 SERIES SPIN FEMALE CONNECTOR,  
 PVC CABLE

DWN: Blues PART NO. 2ME3010-W05238H  
 CHKD: Harlan SCALE 2:1 UNIT: mm  
 APVD: Steve SIZE: A3 SHEET: 1 OF 1 REV: A

CUSTOMER COPY