

REV.	ECN NO.	OR DESCRIPTION	REVISION	DATE
A	PDR NO.:S140723-5B		YF	2014.07.29
B	ECN NO.:S150553-C		Vicky	2015.06.10
C	ECN NO.:S150749-C		Vicky	2015.06.10

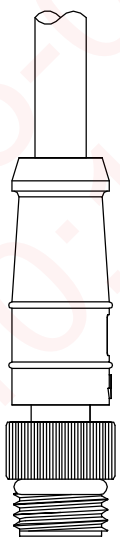

6	BROWN
5	YELLOW
4	BLUE
3	WHITE
2	GREEN
1	BLACK
CONN.	WIRE COLOR

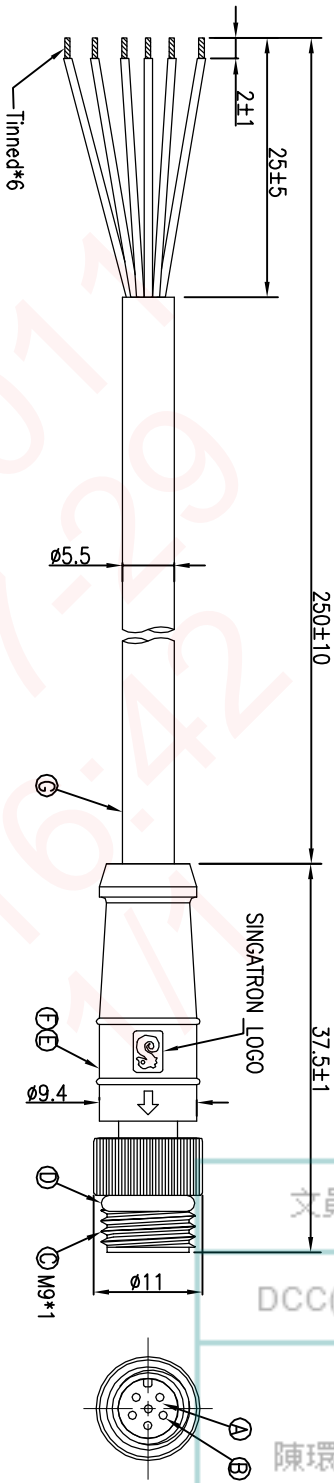
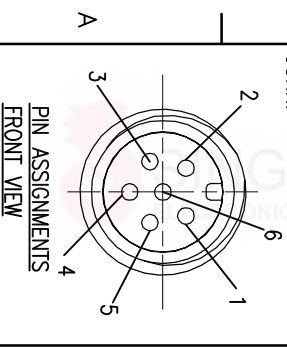

- NOTES:
1. WATERPROOF RATE: IP65
 2. ELECTRICAL CHARACTERISTICS
TEMPERATURE RANGE: -20°C TO +80°C
RATING: 60V AC/DC 2A
 3. SPECIFICATIONS: SEE "M8 SERIES SPECIFICATIONS".
 4. TO CONFORM TO SINGATRON HAZARDOUS SUBSTANCE FREE SPEC.
 5. GREEN PRODUCT IDENTIFICATION LABEL ON PACKAGING:

NO	DESCRIPTION	QTY	MATERIAL	PLATING & COLOR
A	BODY	1	TPU	BLACK
B	MALE PIN	6	BRASS	1" GOLD PLATING OVER NICKEL PLATING
C	NUT	1	C3604	NICKEL PLATING
D	O-RING	1	VITON	BLACK
E	OVER MOLD	1	TPU	BLACK
F	SHRINK TUBE	6	Ø1.5*7mm	BLACK
G	CABLE	1	UL2464 24#*6C+AL OD5.5	BLACK(PVC JACKET)

UNLESS OTHERWISE SPECIFIED TOLERANCES

DECIMALS:	ANGLES:
X :±0.5	X :±2°
X.X :±0.3	X.X :±1°
X.XX :±0.2	

Singatron Enterprise Co., Ltd.
信登企業股份有限公司

TITLE	M9 SERIES MALE CONN. (SPIN)
DWN	Vicky
CHKD	Harten
APVD	Steve

PART NO. 2ME3012-W06204H
SCALE 2:1 UNIT: mm
SIZE: A3 SHEET: 1 OF 1 REV: B

CUSTOMER COPY