

REV.	ECN NO OR DESCRIPTION	REVISED	DATE
A	ECNG120050 UPDATE DRAWING	DAOWEN	2012.04.30

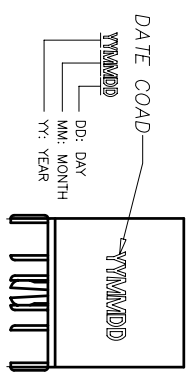

- NOTE:
1. PCB LAYOUT DRAWING: BOTTOM VIEW (SOLDER SIDE)
 2. SPECIFICATIONS: SEE 2MU-0106 SERIES SPECIFICATIONS.
 3. *SEE NO. OF CONTACTS.
 4. SOLDER HEAT RESISTANCE: WAVE SOLDERING 260°C 10SECS.
 5. TO CONFORM TO THE "SE-01-001" & "ROHS DIRECTIVE"
 6. GREEN PRODUCT IDENTIFICATION MARK IN JACK:
 7. GREEN PRODUCT IDENTIFICATION LABEL IN PACKING:
 8. FOR WAVE SOLDERING LEAD-FREE PROCESS.

G.P. PASS

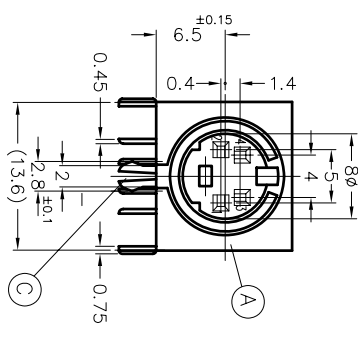
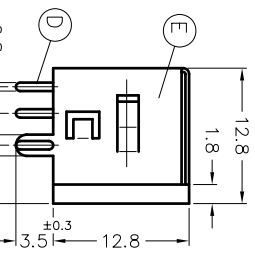
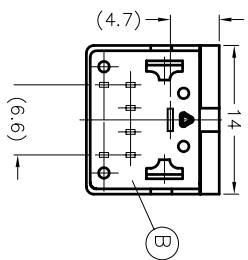
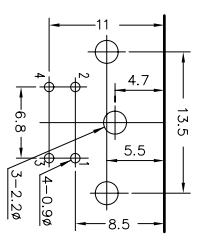

NO	DESCRIPTION	QTY	MATERIAL	PLATING & COLOR
E	SHIELDING PLATE	1	STEEL	TIN(L/F) PLATING
D	CONTACTOR	4	PHOSPHOR BRONZE 0.2t	GOLD FLASH 30u"
C	EARTH TERMINAL	1	BRASS 0.4t	TIN(L/F) PLATING
B	COVER	1	PBT UL 94V-0	BLACK COLOR
A	BODY	1	PBT UL 94V-0	BLACK COLOR

UNLESS OTHERWISE SPECIFIED TOLERANCES

DECIMALS:	ANGLES:
X : ±0.5	X : ±2°
X.X : ±0.3	X.X : ±1°
X.XX : ±0.2	

TITLE	MINIATURE DIN CONNECTOR
DWN	2012.04.30
CHKD	2012.04.30
APVD	2012.04.30

Part No. 2MU-0102G631 SERIES

SCALE: 2/1 UNIT: mm

SIZE: A3 SHEET: 1 OF 1 REV: A

CUSTOMER COPY

Singaton Enterprise Co., Ltd.
信音企業股份有限公司

