

REV.	ECN NO. OR DESCRIPTION	REVISED	DATE
A	PRODUCT RELEASE	Zhenyu	2021.09.16

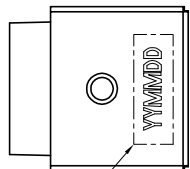

DATE CODE

REMARK:

1. RATING: DC 26V/8.5A.
2. SOLDERING CONDITION: WAVE SOLDERING.
3. MARKING: MARK "S" ON REAR OF CONNECTOR.
4. GREEN PRODUCT IDENTIFICATION MARK ON JACK: **G.P. PASS**
5. GREEN PRODUCT IDENTIFICATION LABEL ON PACKAGING: **G.P. PASS**
6. TO CONFORM TO SINGATRON HAZARDOUS SUBSTANCE FREE SPEC.
7. FOR WAVE SOLDERING LEAD-FREE PROCESS.
8. PRINTED DATE CODE "YMMDD" ON TOP OF CONNECTOR.

DATE CODE: YMMDD

DD: DAY
MM: MONTH
YY: YEAR

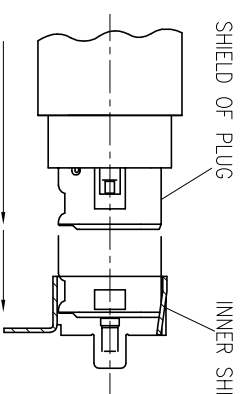
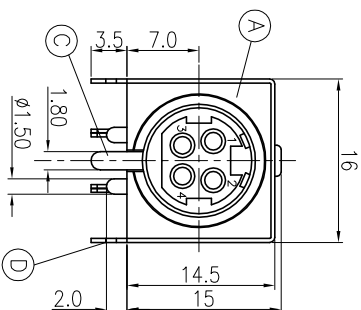
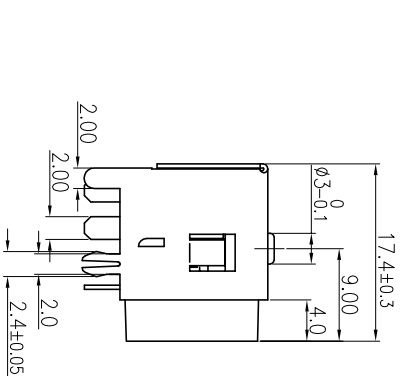

A-A' SECTION OF INNER SHIELD

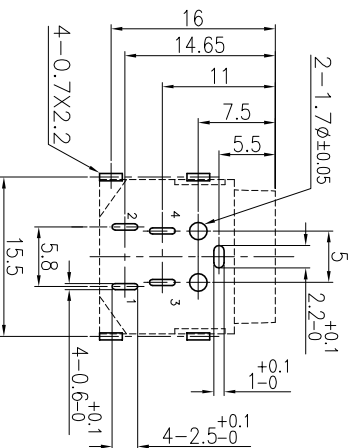

RECOMMENDED PCB LAYOUT
(TOP VIEW)(TOL. ±0.05)

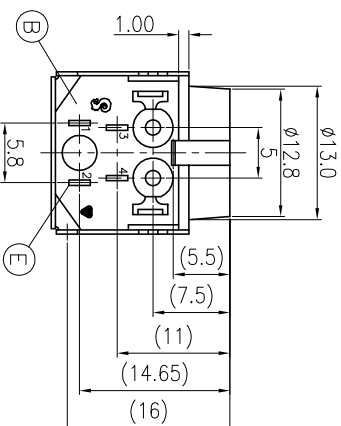

NO.	DESCRIPTION	QTY	MATERIAL	PLATING & COLOR
E	CONTACT TERMINAL	4	PHOSPHOR BRONZE 0.3T	SILVER PLATING
D	OUTER SHIELD	1	BRASS 0.4T	NICKEL 60μ" MIN PLATING
C	INNER SHIELD	1	BRASS 0.4T	NICKEL PLATING
B	COVER	1	THERMOPLASTIC UL94V-0	BLACK COLOR
A	BODY	1	THERMOPLASTIC UL94V-0	BLACK COLOR

UNLESS OTHERWISE SPECIFIED TOLERANCES

DECIMALS: ANGLES:

X : ±0.5 X : ±2°
X.X : ±0.3 X.X : ±1°
X.XX : ±0.2

TITLE	4P SOCKET		
DWN	Zhenyu-Q	PART NO.	2M4-0402A121H
CHKD	Stone-Zhu	SCALE 1:1	UNIT: mm
APVD	jin-deng	SIZE: A3	SHEET: 10F1

REV: A

CUSTOMER COPY

Singatron Enterprise Co., Ltd.
信音企業股份有限公司