

REV.	ECN NO. OR DESCRIPTION	REVISED	DATE
B	增加環保及高溫記號	EVEN	1/28/04
C	ECN NO.920008	BERRYL	2005.10.17
D	MODIFY ACCOUNT OF PLASTIC	Sticky-hu	2010.01.18

- SPECIFICATIONS:
1. SEE "SPEC. OF 2MU-0402 SERIES".
 2. TO CONFORM TO THE "SE-01-001" & "ROHS DIRECTIVE"
 3. GREEN PRODUCT IDENTIFICATION MARK IN JACK: 
 4. GREEN PRODUCT IDENTIFICATION LABEL IN PACKING: **G.P.PASS**
 5. FOR LEAD-FREE PROCESS.

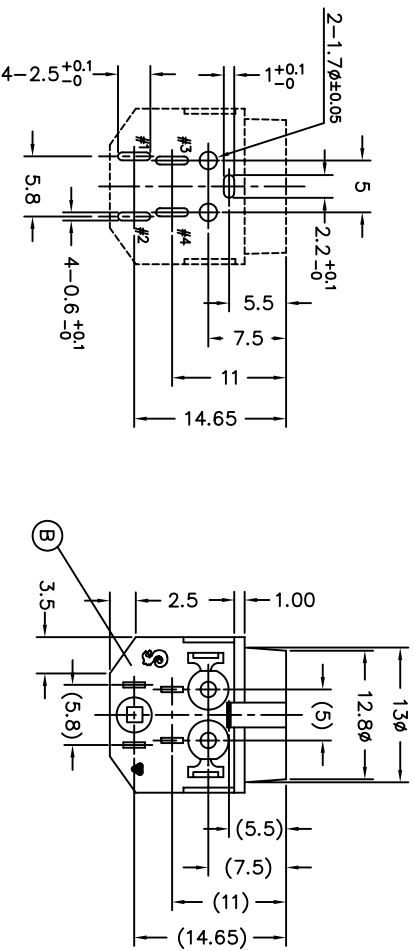
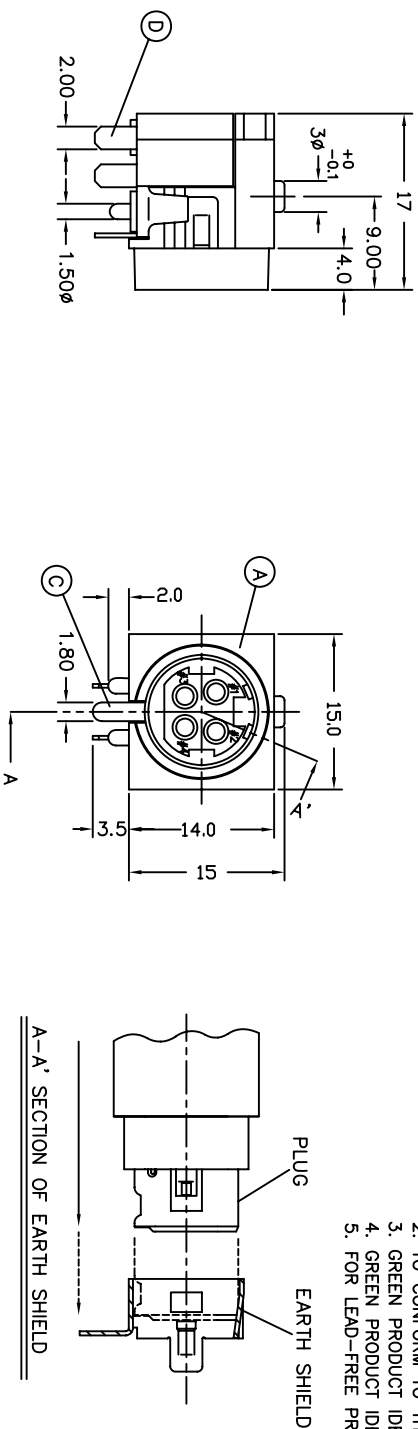

PCB LAYOUT
(SOLDER SIDE)
TOLERANCE: ±0.05

4	CONTACT TERMINAL	4	PHOSPHOR BRONZE 0.3t	SILVER PLATING
3	INNER SHIELD	1	BRASS 0.4t	NICKEL PLATING
2	COVER	1	NLON-9T-30% GF	BLACK COLOR
1	BODY	1	NLON-9T-30% GF	BLACK COLOR
NO	DESCRIPTION	QTY	MATERIAL	PLATING & COLOR

UNLESS OTHERWISE SPECIFIED TOLERANCES

 Singatron Enterprise Co., Ltd.
信晉企業股份有限公司

DECIMALS: ANGLES:

TITLE: 4P SOCKET

X : ±0.5 X : ±2
X.X : ±0.3 X.X : ±1*
X.XX : ±0.2

DWN: Sticky-hu PART NO. 2M1-0402A1H0
CHKD: Myron SCALE: 2/1 UNIT: mm
APVD: hoho SIZE: A3 SHEET: 1 OF 1 REV: D

CUSTOMER COPY