

| REV. | ECN NO OR DESCRIPTION | REVISED | DATE |
|------|----------------------------|-----------|------------|
| A | PRODUCT RELEASE | Connie | 2004.06.29 |
| B | ECN:C110044 MODIFY DRAWING | LONGJIANG | 2011.02.22 |
| C | ECN:C160012 MODIFY DRAWING | CHEN | 2016.02.26 |

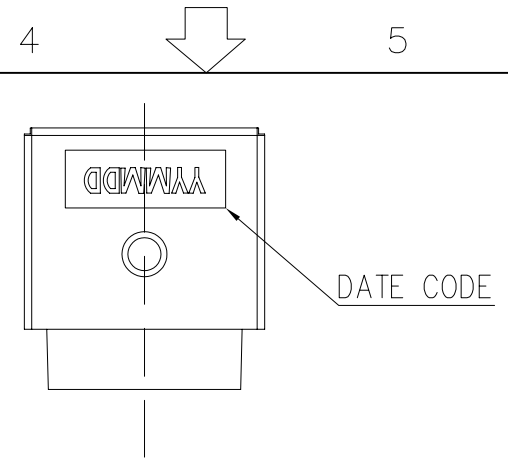

SPECIFICATIONS:

- ELECTRICAL CHARACTERISTICS:**
 - RATING: 20V 7.5A
 - CONTACT RESISTANCE: INITIAL 30mΩ MAX. AFTER LIFE TEST 60mΩ MAX.
 - DIELECTRIC WITHSTANDING VOLTAGE: 250V AC FOR ONE MINUTE.
 - INSULATION RESISTANCE: 100MΩ MIN. MEASURED BY 250V DC
- MECHANICAL CHARACTERISTICS:**
 - INSERTION FORCE : 1.0~4.0 kgf (INITIAL / AFTER LIFE TEST)
 - WITHDRAWAL FORCE : 1.0~4.0 kgf(INITIAL / AFTER LIFE TEST)
- LIFE TEST: 5,000 CYCLES
- OTHER GENERAL SPEC. TO REFER "2MJ-3432 SERIES SPEC".
- TO CONFORM TO SINGATRON HAZARDOUS SUBSTANCE FREE SPEC.
- GREEN PRODUCT IDENTIFICATION LABEL ON PACKAGING:
- GREEN PRODUCT IDENTIFICATION LABEL ON PACKAGING: **G.P. PASS**
- FOR REFLOW SOLDERING LEAD-FREE PROCESS.
- PRINTED DATE CODE "YY MM DD" ON TOP OF CONNECTOR.

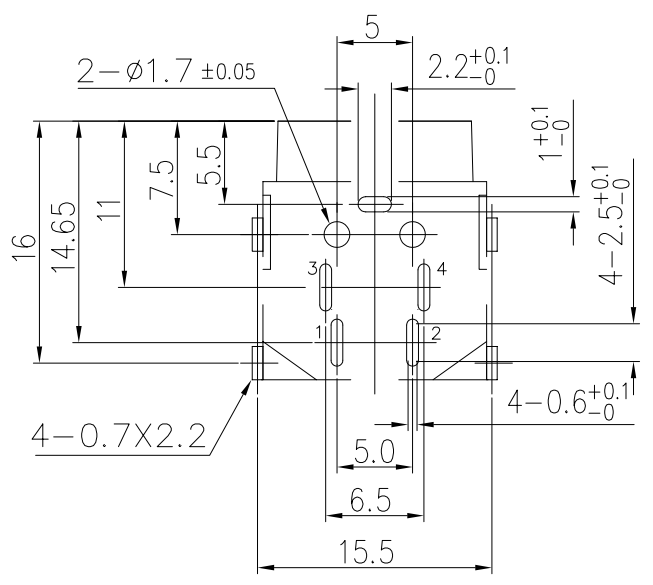
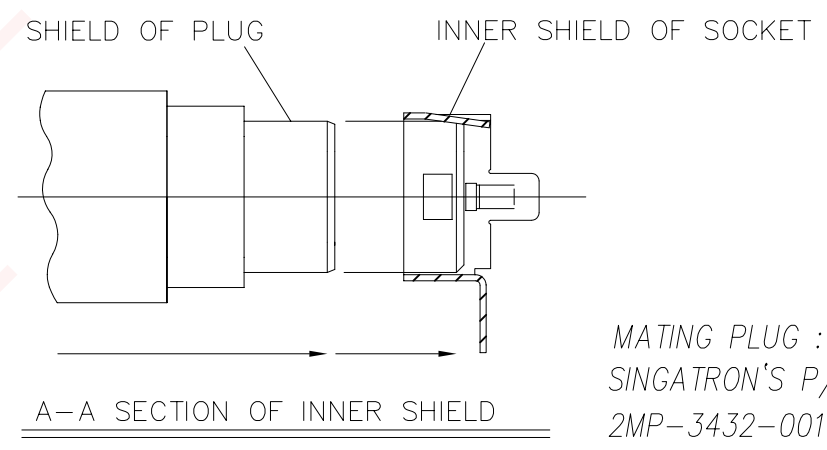
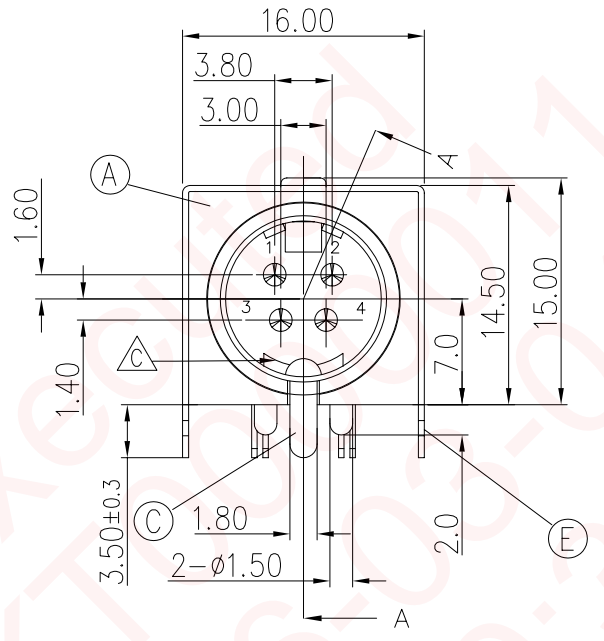
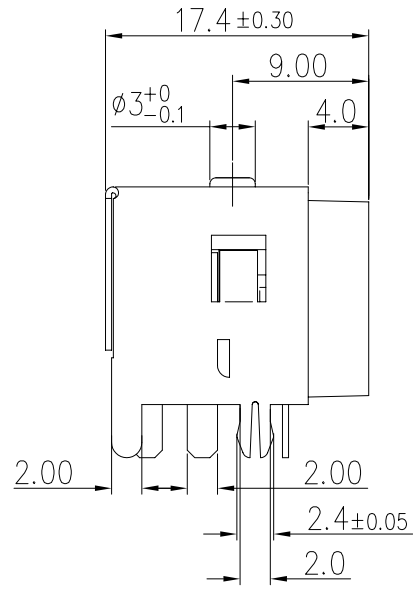
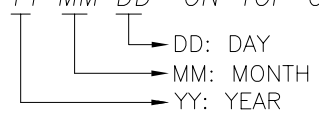

PCB LAYOUT
(SOLDER SIDE)
TOLERANCE: ±0.05

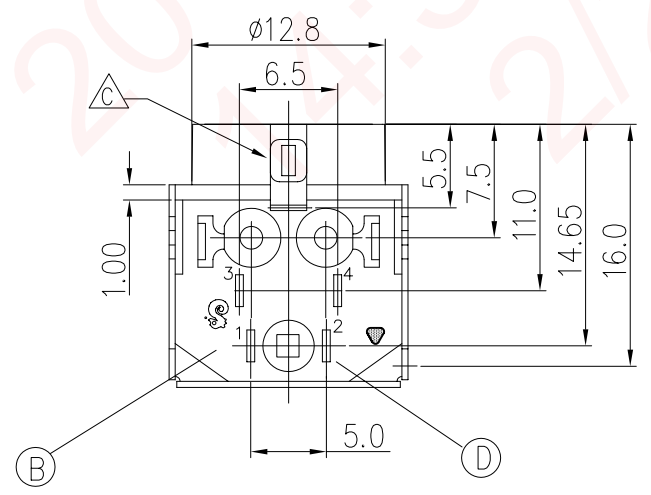

| NO | DESCRIPTION | QTY | MATERIAL | PLATING & COLOR |
|----|--------------|-----|--------------------------|------------------------|
| E | OUTER SHIELD | 1 | BRASS 0.4t | TIN PLATING(LEAD FREE) |
| D | CONTACT PIN | 4 | BRASS 0.3t | SILVER PLATING |
| C | INNER SHIELD | 1 | BRASS 0.4t | NICKEL PLATING |
| B | COVER | 1 | HIGH TEMP. THERMOPLASTIC | BLACK COLOR |
| A | BODY | 1 | UL 94V-0 | BLACK COLOR |

| | | | | |
|---------------------------------------|-----------|--|-----------------------|-------------------------------|
| UNLESS OTHERWISE SPECIFIED TOLERANCES | | Singatron Enterprise Co., Ltd. 信音企業股份有限公司 | | |
| DECIMALS: | ANGLES: | TITLE | 4P SOCKET | |
| X : ±0.5 | X : ±2° | DWN | Chen-Cao 16/03/02 | PART NO. 2MJ-3432-004 |
| X.X : ±0.3 | X.X : ±1° | CHKD | Stone-Zhu 16/03/02 | SCALE 3:1 UNIT: mm |
| X.XX : ±0.2 | | APVD | Zjz-Zhou 16/03/02 | SIZE: A3 SHEET: 1 OF 1 REV: C |
| CUSTOMER COPY | | | | |