

REV.	ECN NO OR DESCRIPTION	REVISED	DATE
A	PRODUCT RELEASE	WANG-TANG	2016.07.26

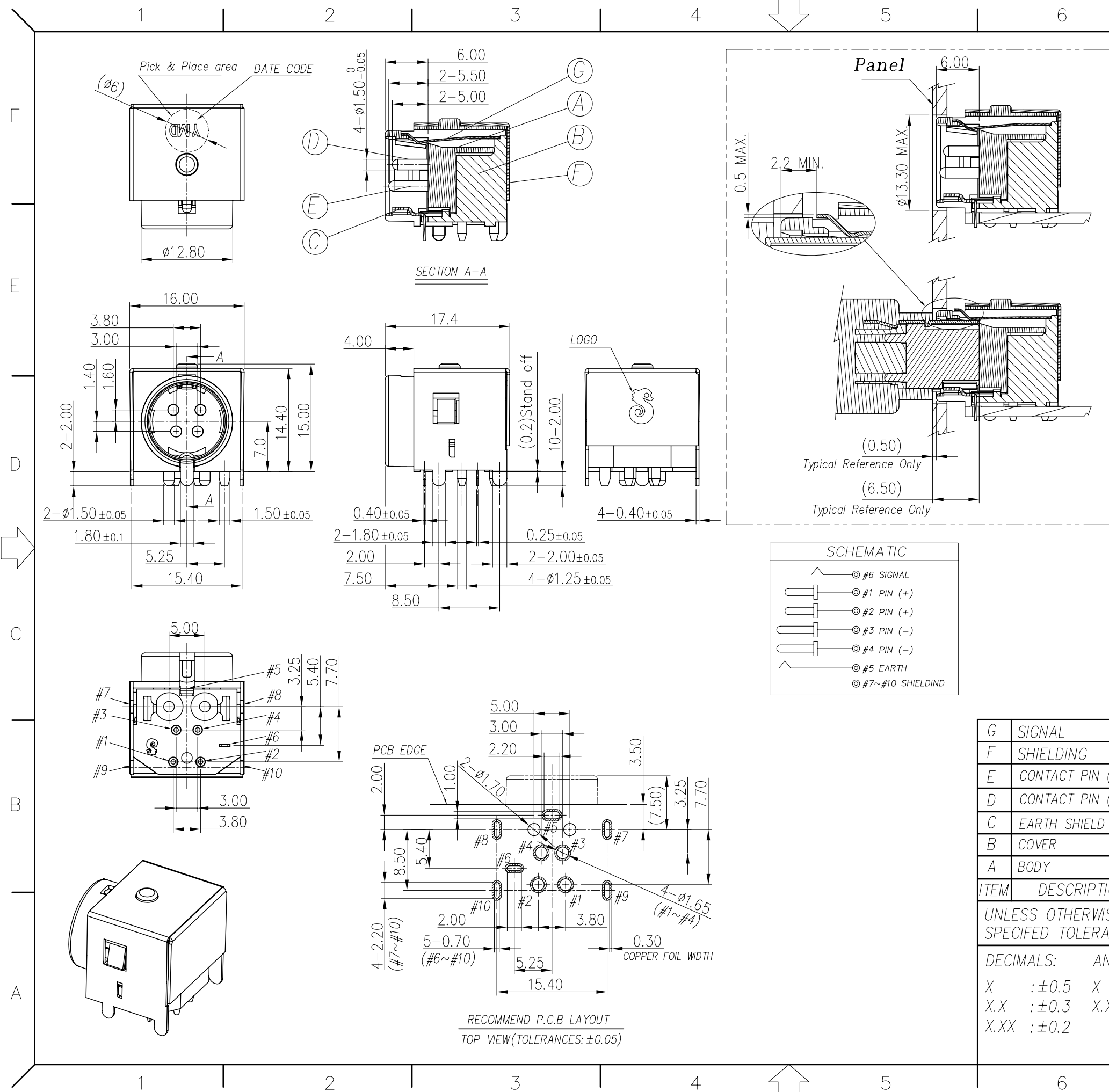

- SPECIFICATIONS:
- ELECTRICAL CHARACTERISTICS:
 - RATING: 20V 18A
 - CONTACT RESISTANCE: POWER PIN(+/-) 5mΩ MAX./PER PIN EARTH / SIGNAL PIN 30mΩ MAX.
 - DIELECTRIC WITHSTANDING VOLTAGE: 500V AC FOR ONE MINUTE.
 - INSULATION RESISTANCE: 100MΩ MIN. MEASURED BY 500 VDC
 - MECHANICAL CHARACTERISTICS:
 - INSERTION FORCE : 1.0~4.0 kgf (INITIAL / AFTER LIFE TEST)
 - WITHDRAWAL FORCE : 1.0~4.0 kgf (INITIAL / AFTER LIFE TEST)
 - TEMPERATURE RISE CAN'T EXCEED 30°C
 - LIFE TEST: 8,000 CYCLES MIN.
 - WEIGHT : 6.6 g (REF.)
 - OTHER GENERAL SPEC. TO REFER "2MJ-3432-012F SPEC".
 - HALOGEN FREE PRODUCT IDENTIFICATION MARK ON JACK: (C)
 - HALOGEN FREE PRODUCT IDENTIFICATION LABEL ON PACKAGING: (C)
 - FOR REFLOW SOLDERING LEAD-FREE PROCESS.
 - PRINTED DATE CODE "Y M D" ON TOP OF CONNECTOR.

D: DAY
M: MONTH
Y: YEAR

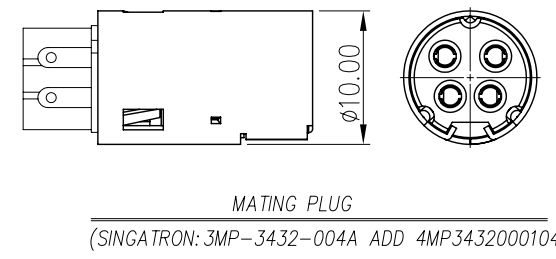
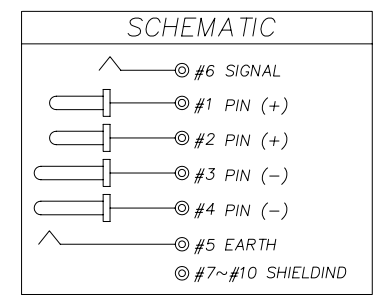

G	SIGNAL	1	PHOSPHOR BRONZE	SN PLATING.
F	SHIELDING	1	BRASS	NI PLATING.
E	CONTACT PIN (-)	2	BRASS	GOLD FLASH PLATING.
D	CONTACT PIN (+)	2	BRASS	GOLD FLASH PLATING.
C	EARTH SHIELD	1	BRASS	NI PLATING.
B	COVER	1	HI-TEMP.THERMOPLASTIC UL94V-0	BLACK
A	BODY	1	HI-TEMP.THERMOPLASTIC UL94V-0	BLACK
ITEM	DESCRIPTION	QTY	MATERIAL	PLATING & COLOR

UNLESS OTHERWISE SPECIFIED TOLERANCES

DECIMALS: ANGLES:

X : ±0.5 X : ±2°
X.X : ±0.3 X.X : ±1°
X.XX : ±0.2

TITLE	4P SOCKET		
DWN	Wang-Tang 16/08/01	PART NO. 2MJ-3432-015F	
CHKD	Stone-Zhu 16/08/01	SCALE 2:1	UNIT: mm
APVD	Zjz-Zhou 16/08/01	SIZE: A3	SHEET: 1 OF 2
REV: A			

CUSTOMER COPY

REV.	ECN NO OR DESCRIPTION	REVISED	DATE
A	PRODUCT RELEASE	WANG-TANG	2016.07.26

1. 負極接觸狀態

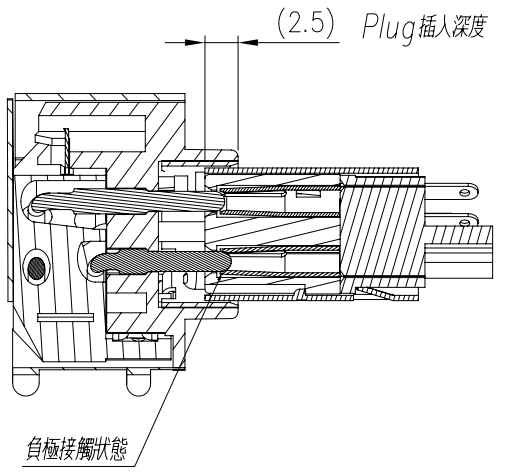

2. 正極接觸狀態

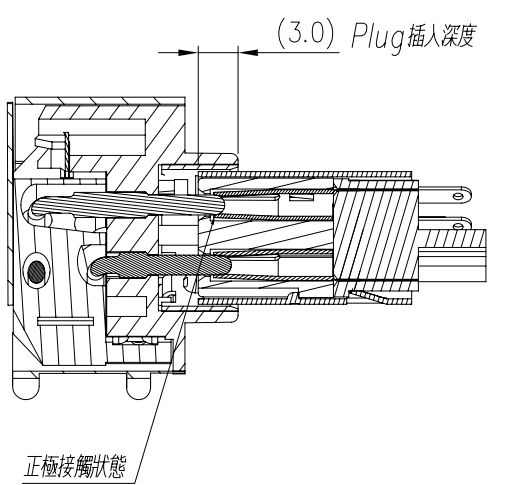

3. 訊號接觸狀態

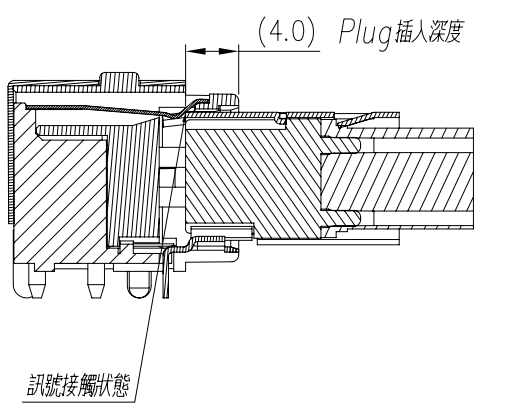

4. plug 插到底狀態

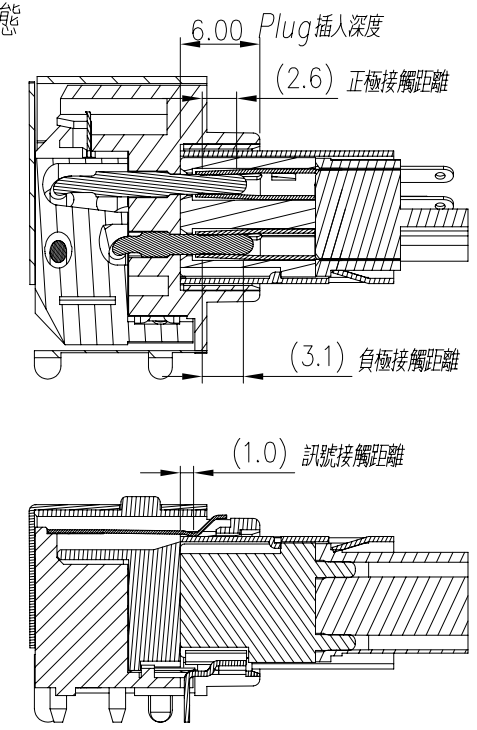

UNLESS OTHERWISE SPECIFIED TOLERANCES

DECIMALS: ANGLES:
 X : ±0.5 X : ±2°
 X.X : ±0.3 X.X : ±1°
 X.XX : ±0.2

Singatron Enterprise Co., Ltd.
 信音企業股份有限公司

TITLE	4P SOCKET_MATING DRAWING		
DWN	Wang-Tang 16/08/01	PART NO. 2MJ-3432-015F	
CHKD	Stone-Zhu 16/08/01	SCALE 2:1	UNIT: mm
APVD	ZJZ-Zhou 16/08/01	SIZE: A3	SHEET: 2 OF 2

CUSTOMER COPY