

REV.	ECN NO OR DESCRIPTION	REVISED	DATE
A	PDR NO:T10042918A	JACY	2010.06.18
B	ECN NO:S130551	SEAN	2013.09.02
C	ECN NO:S141125	KEN	2015.02.10

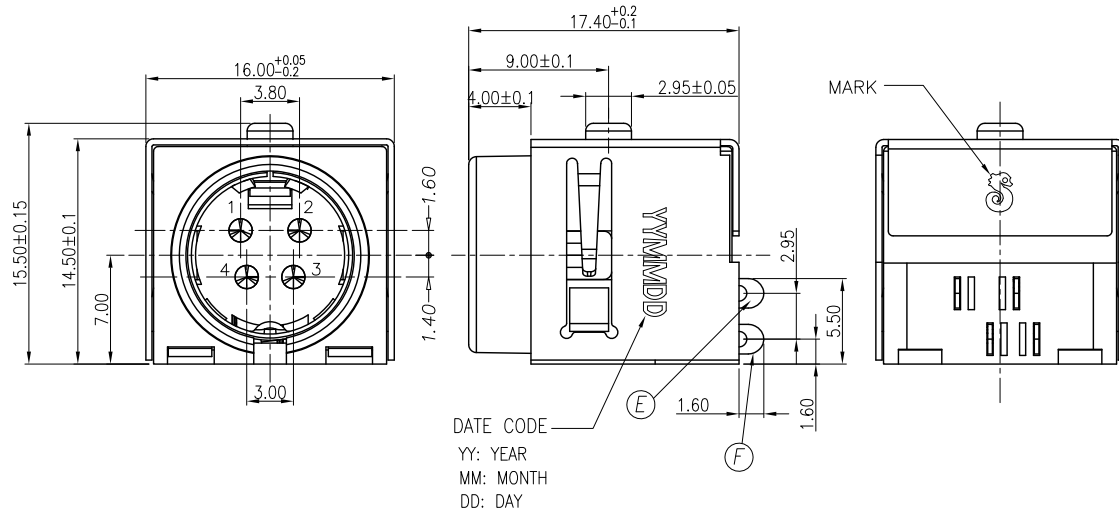

NOTES:

1. SPECIFICATIONS:

(1). ELECTRICAL CHARACTERISTICS:

- 1-1. RATING VOLTAGE: DC 20V 10A
- 1-2. CONTACT RESISTANCE: 30mΩ MAX.(INITIAL)
- 1-3. DIELECTRIC WITHSTANDING VOLTAGE: 250V FOR ONE MINUTE
- 1-4. INSULATION RESISTANCE: 50MΩ MIN. MEASURED BY 250 V DC(INITIAL)

(2). MECHANICAL CHARACTERISTICS:

- 2-1. INITIAL, BEFORE LIFE CYCLE TEST:INSERTION/WITHDRAWAL FORCE:1.5~4.5 KGF.
- 2-2. AFTER LIFE CYCLE TEST:INSERTION/WITHDRAWAL FORCE:1.2~4.5 KGF.

(3). LIFE TEST: 5,000 CYCLES.

(4). OTHER GENERAL SPEC. TO REFER "2MJ3002 SERIES SPEC".

- 2. MATING PLUG : SINGATRON'S P/N : 3MP-3432-002A & 4MP3432000004(PLUG SET)
- 3. HALOGEN FREE PRODUCT IDENTIFICATION MARK ON JACK:
- 4. HALOGEN FREE PRODUCT IDENTIFICATION LABEL ON PACKAGING:
- 5. TO CONFORM TO SINGATRON HAZARDOUS SUBSTANCE FREE SPECIFICATION.
- 6. PRINTED DATE CODE" YMMDD " ON CONNECTOR.

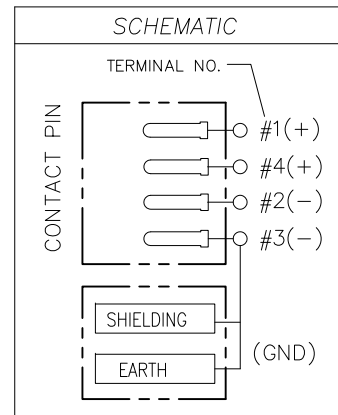
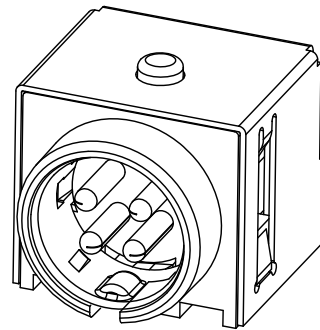
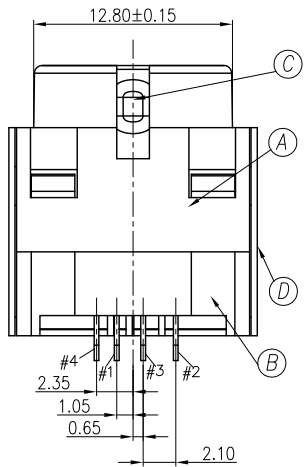

F	LOWER CONTACT PIN	2	BRASS 0.3T	Ni 60u" Min.																
E	UPPER CONTACT PIN	2	BRASS 0.3T	Ni 60u" Min.																
D	SHIELDING	1	BRASS 0.4T	Ni 60u" Min.																
C	EARTH	1	BRASS 0.4T	Ni 60u" Min.																
B	COVER	1	HIGH TEMP. THERMOPLASTIC	BLACK																
A	BODY	1	HIGH TEMP. THERMOPLASTIC	BLACK																
NO	DESCRIPTION	QTY	MATERIAL	PLATING & COLOR																
UNLESS OTHERWISE SPECIFIED TOLERANCES		Singatron Enterprise Co., Ltd. 信音企業股份有限公司																		
DECIMALS: X :±0.5 X.X :±0.3 X.XX :±0.2		ANGLES: X :±2° X.X :±1°		<table border="1"> <thead> <tr> <th>TITLE</th> <th colspan="3">MINI DIN 4 POS. CONN.</th> </tr> </thead> <tbody> <tr> <td>DWN</td> <td>Ken</td> <td colspan="2"><b>PART NO. 2MJ3002-104312</b></td> </tr> <tr> <td>CHKD</td> <td>cerry</td> <td>SCALE:4:1</td> <td>UNIT: mm</td> </tr> <tr> <td>APVD</td> <td>lussen</td> <td>SIZE: A3</td> <td>SHEET:1 OF 1</td> </tr> </tbody> </table>	TITLE	MINI DIN 4 POS. CONN.			DWN	Ken	<b>PART NO. 2MJ3002-104312</b>		CHKD	cerry	SCALE:4:1	UNIT: mm	APVD	lussen	SIZE: A3	SHEET:1 OF 1
TITLE	MINI DIN 4 POS. CONN.																			
DWN	Ken	<b>PART NO. 2MJ3002-104312</b>																		
CHKD	cerry	SCALE:4:1	UNIT: mm																	
APVD	lussen	SIZE: A3	SHEET:1 OF 1																	
<b>CUSTOMER COPY</b>																				