

REV.	ECN.NO.	DATE
A	RELEASED	04/27-'07
B	Add the Screw	04/26-'12

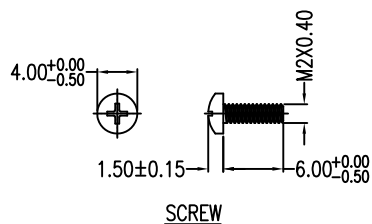
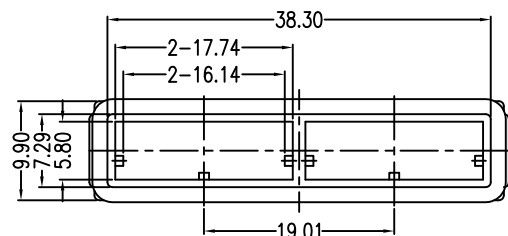

**NOTES:**

**\*Material**

Body: Zn Alloy  
 Plating: Ni Plating Over All  
 Cover: SUS  
 EMC Gasket: Elastomer, UL94V-0

**\*Mechanical**

The Cable Retention Force: 20lbf Min

**\*Others**

Our Company's Usual Specification is Without Screw

**\*How to Order:**

2MSA-S26-R5S-20  
 Blank: 2X(Without Screw)  
 S: 2X(With Screw)  
 Series NO.

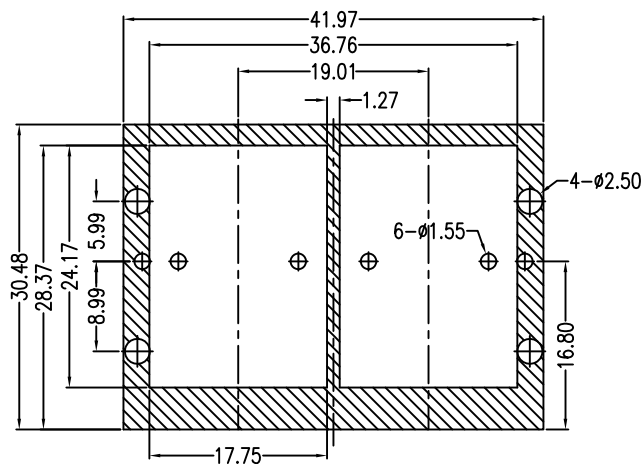
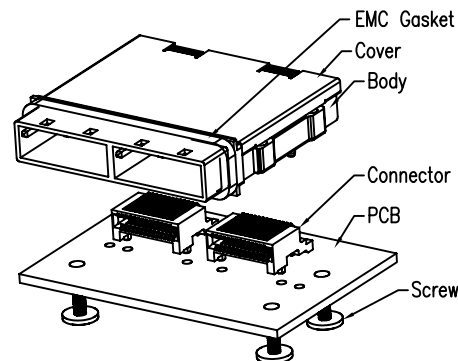
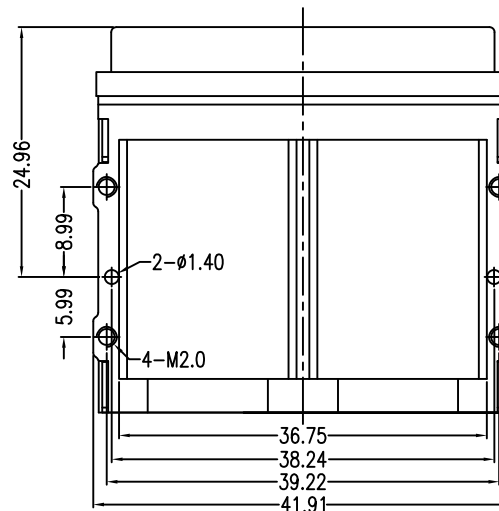
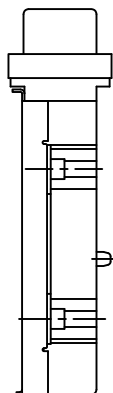
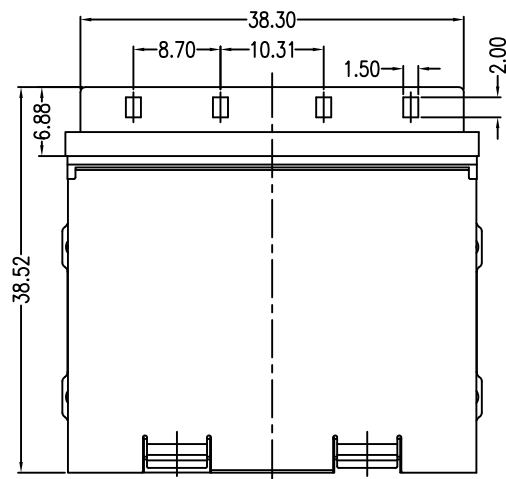

P.C.B LAYOUT  
COMPONENT SIDE

Units	mm	Scale	3:2	Drawing By	Data	SINGATRON U.S.A.			
Tolerance Unless Otherwise Specified				May	04/26/12				
.X ~ ±0.38				Reviewed By	Data	Date	04/26-'12		
.XX ~ ±0.25				Sharon	04/26/12	Sheet	1 of 1	Title	
.XXX ~ ±0.20				Approval By	Data	Third Angle Projection		Mini SAS 26P Shell(2X)	
Angle ~ ± 3°				Jason	04/30/12	Drawing No.	2MSA-S26-R5S-20	REV	B