

REV	ECN NO	OR DESCRIPTION	REVISED	DATE
A	PDR NO.:S131206-3E	Shown	2014.08.06	

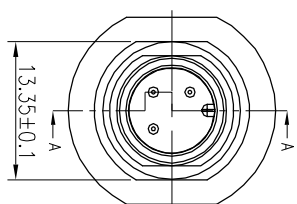

INCIDENTAL SHIPMENT, NO NEED ASSEMBLY
HEX NUT IN A BAG AND NOTE THE CUSTOMER P/N IN LABEL

CUSTOMER P/N SINGATRON P/N
EC09H1203901009 ZMT3003-W03303H

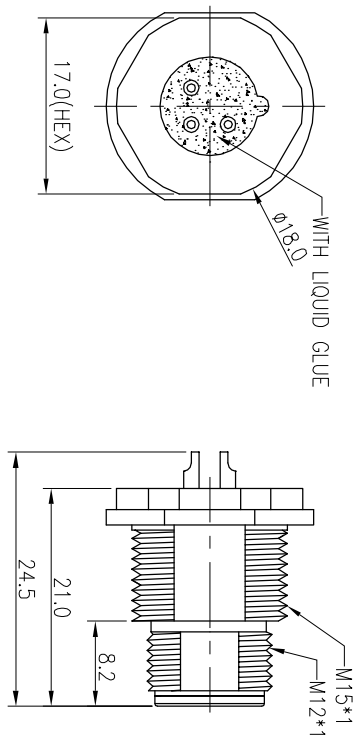
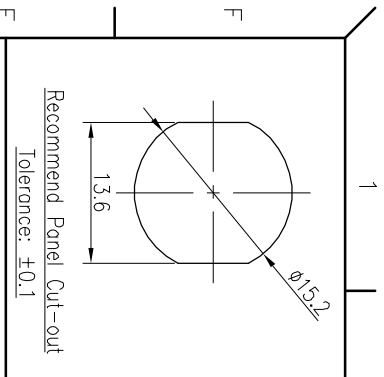
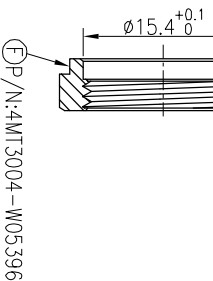
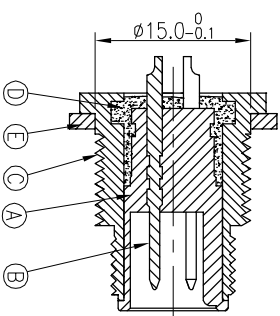

SECTION A-A

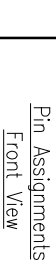
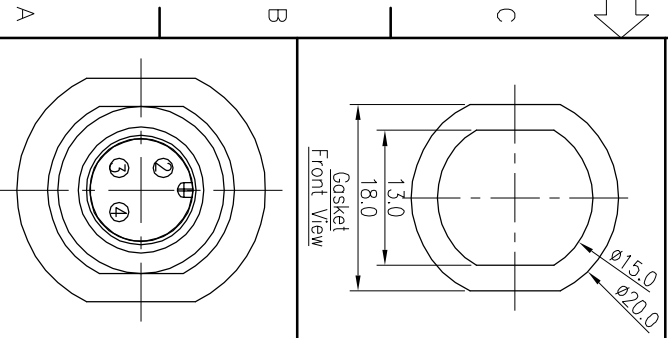

- NOTES:
1. WATERPROOF RATE: IP66/IP67
 2. ELECTRICAL CHARACTERISTICS
TEMPERATURE RANGE: -40°C TO +100°C
RATING: 60V AC/DC 5A
 3. SPECIFICATIONS:SEE "M12 SERIES SPECIFICATIONS" ..
 4. TO CONFORM TO ROHS REQUIREMENT AND REACH REGULATION
 5. GREEN PRODUCT IDENTIFICATION LABEL ON PACKAGING:
 6. NON-HUMAN FACTORS CASE SERVICE LIFE IS 5 YEARS
 7. TORQUE FORCE: 0.8~1.0N.m
 8. FOR PANEL THICKNESS MAX OF 4.0mm
 9. SUS 316F OR SAME GRADE THAT CAN PASS 200H SALT SPRAY TEST

F	DESCRIPTION	QTY	MATERIAL	PLATING & COLOR
F	NUIT	1	SEE"NOTE 9"	N/A
E	GASKET	1	SILICON	BLACK
D	LIQUID GLUE	1	N/A	BLACK
C	SHIELD	1	SEE"NOTE 9"	N/A
B	MALE PIN	3	BRASS	6μ" GOLD PLATING OVER NICKEL PLATING
A	BODY	1	PA66+GF	BLACK
NO	DESCRIPTION	QTY	MATERIAL	PLATING & COLOR

UNLESS OTHERWISE SPECIFIED TOLERANCES

TITLE M12 SERIES FRONT MOUNT MALE CONN.

Singatron Enterprise Co., Ltd.
信登企業股份有限公司

DECIMALS: ANGLES:

DWN Shown PART NO.2MT3003-W03303H
CHKD JF SCALE 2:1 UNIT: mm
APVD Harlen SIZE: A3 SHEET:1 OF 1 REV: A

CUSTOMER COPY