

REV.	ECN NO.	OR DESCRIPTION	REVISED	DATE
A	PDR NO.:S151230-10A	Vcky		2015.09.08

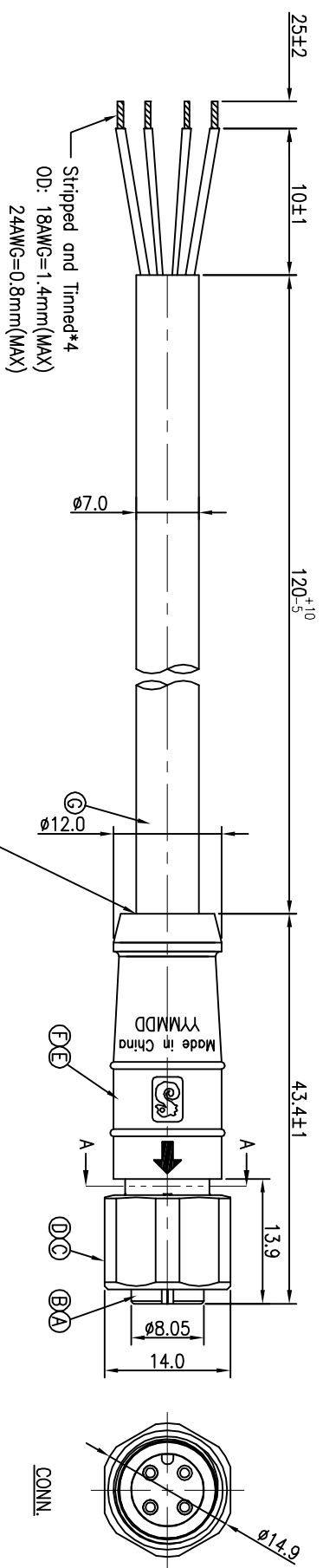

CUSTOMER P/N	SINGATRON P/N
MHCAH90140530	ZMT3010-W043A6H

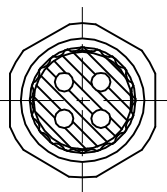

BLACK	4
BLUE	3
WHITE	2
BROWN	1
WIRE COLOR	CONN.
PIN OUT	

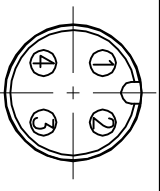

- NOTES:
1. WATERPROOF RATE: IP66/IP67
 2. ELECTRICAL CHARACTERISTICS
TEMPERATURE RANGE: -40° TO +80°
RATING: 60V AC/DC 6.2A
TEST CONDITION: DC300V 10Mohm 10ms
 3. SPECIFICATIONS: SEE "M12 SERIES SPECIFICATIONS".
 4. TO CONFORM TO ROHS REQUIREMENT AND REACH REGULATION
 5. GREEN PRODUCT IDENTIFICATION LABEL ON PACKAGING:
 6. NON-HUMAN FACTORS CASE SERVICE LIFE IS 5 YEARS
 7. TORQUE FORCE: 0.8~1.0N.m
 8. SUS 316F OR SAME GRADE THAT CAN PASS 200H SALT SPRAY TEST
 9. LASE DATE CODE "YMMDD" ON TOP OF OVER MOLD
- DATE CODE: YMMDD
- DAY MONTH YEAR

Pin Assignments
Front View

QTY	DESCRIPTION	MATERIAL	PLATING & COLOR
1	CABLE	UL20549(-40°~+80°) 18#*2C+24#*1P UV RESISTANT OD=φ7.0	BLACK (PU JACKET)
1	OVER MOLD	TPU	BLACK
1	INNER MOLD	TPU	NATURAL
1	O-RING	VITON	RED
1	SCREW NUT	SEE "NOTE 8"	NATURAL
4	FEMALE PIN	Phosphor Bronze	6u" GOLD PLATING OVER NICKEL PLATING
1	BODY	TPU	BLACK

UNLESS OTHERWISE SPECIFIED TOLERANCES

DECIMALS: ANGLES:

X :±0.5 X :±2
X.X :±0.3 X.X :±1'
X.XX :±0.2

Singatron Enterprise Co., Ltd.
信亨企業股份有限公司

TITLE: M12 SERIES 180° 4PIN FEMALE CONN.

DWN: Vcky PART NO. ZMT3010-W043A6H
CHKD: Harten SCALE 2:1 UNIT: mm
APVD: Steve SIZE: A3 SHEET: 1 OF 1 REV: A

CUSTOMER COPY