

REV	ECN NO OR DESCRIPTION	REVISED	DATE
A	PDR NO.:S151202-10A	Blues	2016.11.17

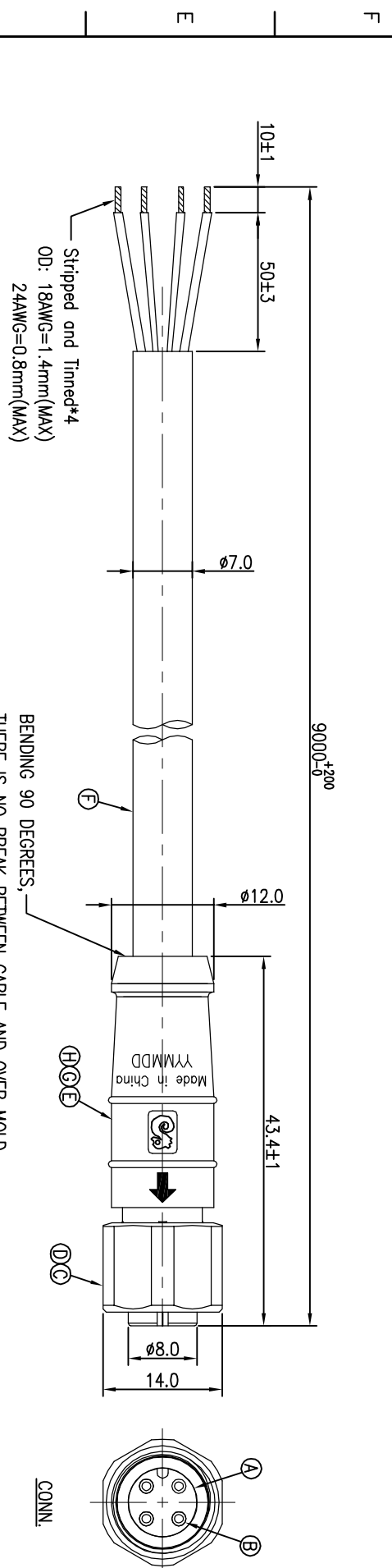

BLACK	4
BLUE	3
WHITE	2
BROWN	1
WIRE COLOR	CONN.
PIN OUT	

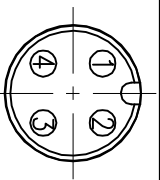

- NOTES:
1. WATERPROOF RATE: IP66/IP67
 2. ELECTRICAL CHARACTERISTICS
TEMPERATURE RANGE: -40° TO +80°
RATING: 60V AC/DC 6.2A
TEST CONDITION: DC300V 10mohm 10ms
 3. SPECIFICATIONS: SEE "M12 SERIES SPECIFICATIONS".
 4. TO CONFORM TO ROHS REQUIREMENT AND REACH REGULATION
 5. GREEN PRODUCT IDENTIFICATION LABEL ON PACKAGING:
 6. NON-HUMAN FACTORS CASE SERVICE LIFE IS 5 YEARS
 7. TORQUE FORCE: 0.8~1.0N.m
 8. SUS 316F OR SAME GRADE THAT CAN PASS 200H SALT SPRAY TEST
 9. LASE DATE CODE "YYMMDD" ON TOP OF OVER MOLD

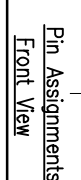
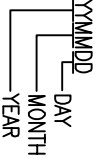

H	HEAT SHRINK TUBE	4	125° 300V Ø3.0	BLACK
G	INNER MOLD	1	TPU(T198A)	NATURAL
F	CABLE	1	UL20549(-40°~+80°) 18#*2C+24#*1P UV RESISTANT OD=Ø7.0	BLACK (PU JACKET)
E	OVER MOLD	1	TPU	BLACK
D	O-RING	1	VITON	RED
C	SCREW NUT	1	SEE"NOTE 8"	N/A
B	FEMALE PIN	4	Phosphor Bronze	6u" GOLD PLATING OVER NICKEL PLATING
A	BODY	1	TPU	BLACK
NO	DESCRIPTION	QTY	MATERIAL	PLATING & COLOR
UNLESS OTHERWISE SPECIFIED TOLERANCES				
Singatron Enterprise Co., Ltd. 信管企業股份有限公司				
TITLE M12 SERIES 180° 4PIN FEMALE CONN.				
DWN Blues PART NO.2MT3010-W043A8H				
CHKD Harten SCALE 1:1 UNIT: mm				
APVD Steve SIZE: A3 SHEET: 1 OF 1 REV:A				
CUSTOMER COPY				

1 2 3 4 5 6 7 8