

REV.	ECN NO OR DESCRIPTION	REVISED	DATE
A	PDR NO.:S160223-6B	Vcky	2016.03.07

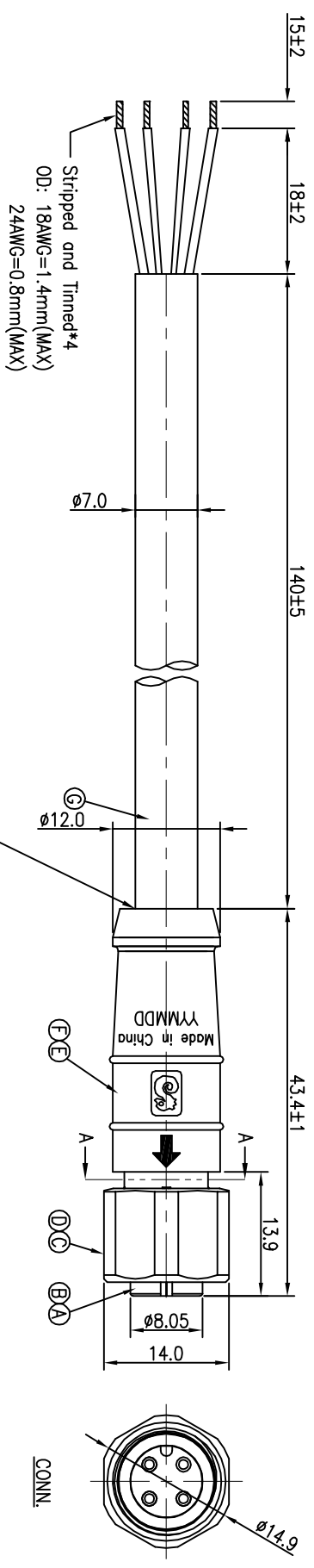

CUSTOMER P/N	SINGATRON P/N
MHCAH90140540	ZMT3010-W043B5H

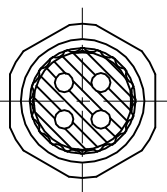

BLACK	4
BLUE	3
WHITE	2
BROWN	1
WIRE COLOR	CONN.
PIN OUT	

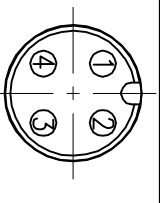

- NOTES:
1. WATERPROOF RATE: IP66/IP67
  2. ELECTRICAL CHARACTERISTICS  
TEMPERATURE RANGE: -40° TO +80°  
RATING: 60V AC/DC 6.2A  
TEST CONDITION: DC300V 10Mohm 10ms
  3. SPECIFICATIONS: SEE "M12 SERIES SPECIFICATIONS".
  4. TO CONFORM TO ROHS REQUIREMENT AND REACH REGULATION
  5. GREEN PRODUCT IDENTIFICATION LABEL ON PACKAGING:
  6. NON-HUMAN FACTORS CASE SERVICE LIFE IS 5 YEARS
  7. TORQUE FORCE: 0.8~1.0N.m
  8. SUS 316F OR SAME GRADE THAT CAN PASS 200H SALT SPRAY TEST
  9. LASE DATE CODE "YYMMDD" ON TOP OF OVER MOLD
- DATE CODE: YYMMDD
- DAY MONTH YEAR

Pin Assignments  
Front View

NO	DESCRIPTION	QTY	MATERIAL	PLATING & COLOR
G	CABLE	1	UL20549(-40°~+80°) 18#*2C+24#*1P UV RESISTANT OD=Ø7.0	BLACK (PU JACKET)
F	OVER MOLD	1	TPU	BLACK
E	INNER MOLD	1	TPU	NATURAL
D	O-RING	1	VITON	RED
C	SCREW NUT	1	SEE "NOTE 8"	NATURAL
B	FEMALE PIN	4	Phosphor Bronze	6u" GOLD PLATING OVER NICKEL PLATING
A	BODY	1	TPU	BLACK

UNLESS OTHERWISE SPECIFIED TOLERANCES

DECIMALS: ANGLES:

X :±0.5 X :±2  
X.X :±0.3 X.X :±1'  
X.XX :±0.2

Singatron Enterprise Co., Ltd.  
 信益企業股份有限公司  
 TITLE: M12 SERIES 180° 4PIN FEMALE CONN.  
 DWG: Vcky PART NO. ZMT3010-W043B5H  
 CHKD: Harten SCALE 2:1 UNIT: mm  
 APVD: Steve SIZE: A3 SHEET: 1 OF 1 REV: A

CUSTOMER COPY