

REV.	ECN NO OR DESCRIPTION	REVISED	DATE
A	PDR NO.:S160616-5A	Vicky	2016.06.16

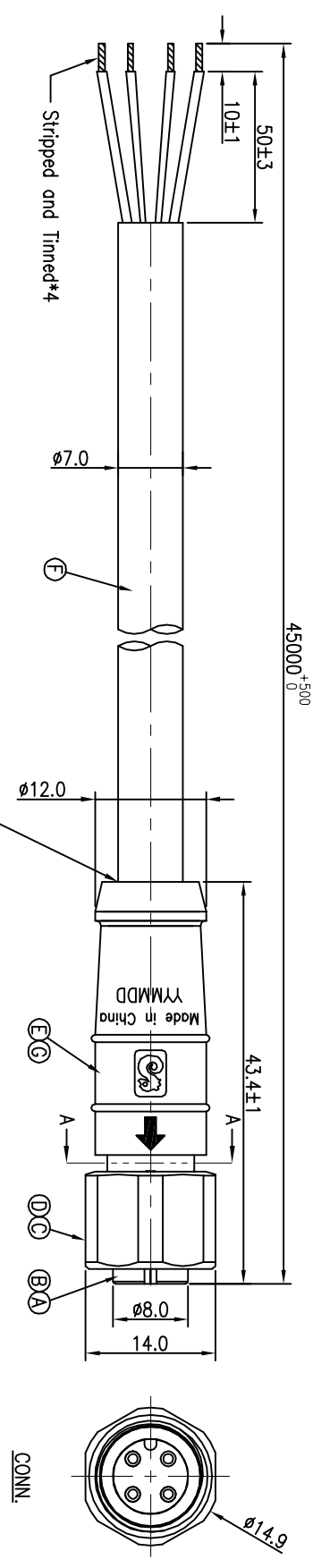

CUSTOMER P/N	SINGATRON P/N
TUAC.0202801	2MT3010-W043B6H

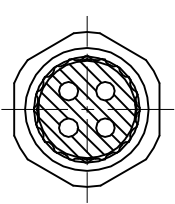

SECTION A-A

BLACK	4
BLUE	3
WHITE	2
BROWN	1
WIRE COLOR	CONN.
PIN OUT	

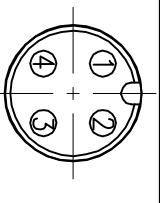

- NOTES:
1. WATERPROOF RATE: IP66/IP67
 2. ELECTRICAL CHARACTERISTICS
TEMPERATURE RANGE: -40° TO +80°
RATING: 60V AC/DC 6.2A
TEST CONDITION: DC300V 10Mohm 10ms
 3. SPECIFICATIONS: SEE "M12 SERIES SPECIFICATIONS".
 4. TO CONFORM TO ROHS REQUIREMENT AND REACH REGULATION
 5. GREEN PRODUCT IDENTIFICATION LABEL ON PACKAGING:
 6. NON-HUMAN FACTORS CASE SERVICE LIFE IS 5 YEARS
 7. TORQUE FORCE: 0.8~1.0N.m
 8. SUS 316F OR SAME GRADE THAT CAN PASS 200H SALT SPRAY TEST
 9. LASE DATE CODE "YYMMDD" ON TOP OF OVER MOLD
- DATE CODE: YYMMDD
- DAY MONTH YEAR

Pin Assignments
Front View

G	INNER MOLD	1	TPU	NATURAL
F	CABLE	1	UL20549(-40°~+80°) 18#*2C+24#*1P UV RESISTANT OD=φ7.0	BLACK (PU JACKET)
E	OVER MOLD	1	TPU	BLACK
D	O-RING	1	VITON	RED
C	SCREW NUT	1	SEE NOTE 8"	N/A
B	FEMALE PIN	4	Phosphor Bronze	6u" GOLD PLATING OVER NICKEL PLATING
A	BODY	1	TPU	BLACK
NO	DESCRIPTION	QTY	MATERIAL	PLATING & COLOR
UNLESS OTHERWISE SPECIFIED TOLERANCES				
DECIMALS: ANGLES:				
X	:±0.5	X	:±2	
X.X	:±0.3	X.X	:±1'	
X.XX	:±0.2			
TITLE M12 SERIES 180° 4PIN FEMALE CONN.				
SINGATRON ENTERPRISE CO., LTD. 信登企業股份有限公司				
DWG Vicky PART NO. 2MT3010-W043B6H				
CHKD Harlen SCALE 2:1 UNIT: mm				
APVD Steve SIZE: A3 SHEET: 1 OF 1 REV: A				
CUSTOMER COPY				